

**ASAIR**®

# Oxygen Sensor

**Product Manual**

**AO-09**



## Features

- Meets ISO 80601-2-55
- Linear output from 0% to 100%
- No external power supply
- Temperature compensation
- Excellent signal stability
- Accurate and reliable
- Fast response
- Anti-interference
- Long lasting

## Summary

AO-09 is the oxygen sensor of Aosong Electronics. Offering long life and fast response, the high quality AO-09 replacement sensor incorporates a molded body design, specific for medical use. Best of all, the AO-09 costs less than the sensors it replaces, creating additional saving while providing superior quality. For further information on the AO-09 or any product in ASAIR's complete line of medical oxygen

analyzers and sensors, contact us.

## Applications

AO-09 Medical Oxygen Sensors are intended as oxygen-sensing component of an oxygen analyzer that measures oxygen concentration in breathing gas mixtures in the following applications:

- Sensing device for oxygen
- Control device of oxygen concentrators
- Medical ventilators
- Anaesthesia equipment
- Incubators

The use is limited to system monitoring. The sensors are not suited for breath by breath analysis of breath gases. Please refer to the instructions for use. To avoid cross infection, please strictly follow the instructions of the oxygen analyzer manufacturer.

# 1 Technical Specifications

MEASUREMENT	
Operating Principle	Partial pressure electrochemical
Output	9 mV to 13 mV in 210 mBar O <sub>2</sub>
Measurement Range	0 - 100 Vol.% O <sub>2</sub>
Response Time (T <sub>90</sub> )	<15 s
Baseline Offset	<200μV
Accuracy	meets ISO 80601-2-55 requirements
Cross interference	meets ISO 80601-2-55 requirements
ELECTRICAL	
Temperature Compensation	<2% O <sub>2</sub> equivalent (0°C-40°C)
External Load Resistor	≥ 10 kΩ
Connector	3P2.5
MECHANICAL	
Housing Material	White ABS
Weight	36 g (nominal)
Orientation	Any
Influence of Mechanical Shock	< 1 % relative after a fall from 1 m
ENVIRONMENTAL	
Typical Applications	Critical care anesthesia
Operating Temperature Range	0°C ~ +50°C
Operating Pressure Range	0.5 Bar - 2.0 Bar
Operating Humidity Range	0% to 99% RH noncondensing
LIFETIME	
Long-Term Output Drift in 100% O <sub>2</sub>	< 5% signal loss/year
Recommended Storage Temperature	10°C - 30°C
Expected Operating Life:	
20°C	1.5 x 10 <sup>6</sup> %O <sub>2</sub> hours
40°C	0.8 x 10 <sup>6</sup> %O <sub>2</sub> hours
Standard Warranty	13 months from date of despatch

Note:

- ① Specifications are based on measurements made with cylinder gases using a flow rate of 100 mls/min and are valid at 20°C, 50% RH and 1013 mBar, using recommended circuitry.
- ② Performance characteristics outline the performance of sensors supplied within the first 3 months.

- ③ Output signal can drift below the lower limit over time.
- ④ Use of a regression coefficient shows a best fit straight line better than 0.9995 when measured through the four data points from testing with 100%N<sub>2</sub>、 21%O<sub>2</sub> 、 60%O<sub>2</sub> and 100%O<sub>2</sub>.
- ⑤ Connection should be made via recommended mating parts only. Soldering to the sensor will damage it and invalidate the warranty.

## 2 Product Dimensions (unit: mm)

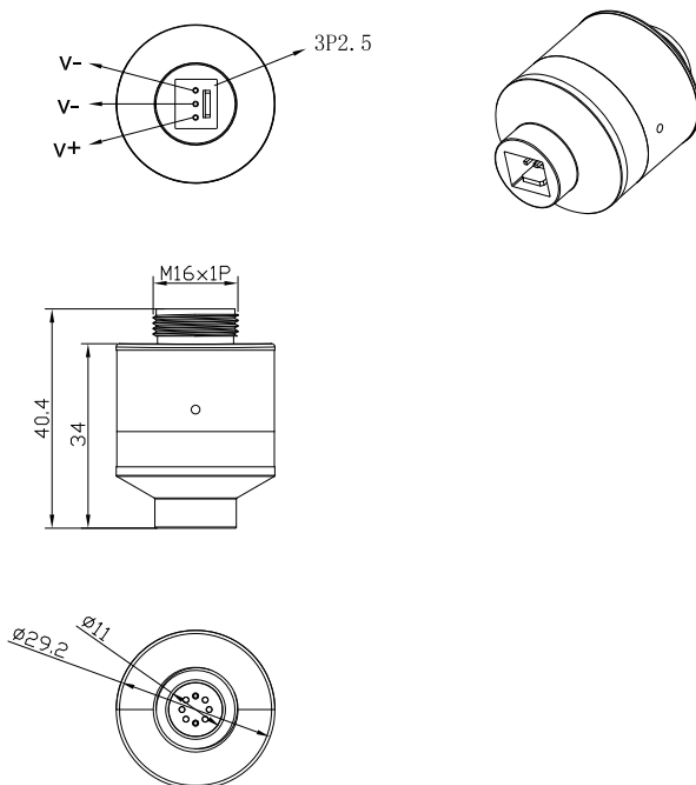

AO-09 outline dimensions

## 3 Installation and Use

### 3.1 Installation requirements

AO-09 is designed for operation in a wide range of environments and harsh conditions. However, it is important that exposure to high concentrations of solvent vapours is avoided, both during storage, fitting into instruments and operation.

When using sensors with printed circuit boards (PCBs), degreasing agents should be used before the sensor is fitted (Clean the PCB to prevent rosin and other flux impurities from volatilizing and condense and block the oxygen sensor breathable membrane). Do not glue directly on or near the AO-09 as the solvent

may cause crazing of the plastic.

### 3.2 Stabilisation Time

Allow at least 15 minutes to stabilise in the instrument before calibration or refer to manufacturers instructions.

### 3.3 Cleaning

In case of contamination the sensor may be cleaned with distilled water and allowed to dry naturally. The sensor is not suitable for sterilisation by steam or exposure to chemicals such as ethylene oxide or hydrogen peroxide.

### 3.4 Calibration Interval

These sensors are designed to have minimal drift over their useful lifetime. For maximum accuracy however they should be calibrated before each use.

### 3.5 If the Sensor is Dropped

If a sensor is dropped, then it should be placed in quarantine for 24 hours and a follow-up check made by a 2 point calibration.

### 3.6 Mechanical Installation

When installing the sensor, it must only be screwed in hand-tight and a gas tight seal ensured. Spanners and similar mechanical aids may not be used, as excessive force may damage the sensor thread.

### 3.7 Cross Sensitivity

Test Gas	% O <sub>2</sub> Error
50% He / 50% O <sub>2</sub>	< 1%
60% N <sub>2</sub> O / 40% O <sub>2</sub>	< 1%
2% Halothane / 40% O <sub>2</sub> / 30% N <sub>2</sub> O / 5% CO <sub>2</sub> / Bal N <sub>2</sub>	< 1.5%
2% Enflurane / 40% O <sub>2</sub> / 30% N <sub>2</sub> O / 5% CO <sub>2</sub> / Bal N <sub>2</sub>	< 1.5%
2% Isoflurane / 40% O <sub>2</sub> / 30% N <sub>2</sub> O / 5% CO <sub>2</sub> / Bal N <sub>2</sub>	< 1.5%

## 4 Warnings and Precautions

4.1 It is the responsibility of the user to determine the suitability for use of the sensor. Follow the instructions for use of the oxygen analyzer and for replacement of oxygen sensor.

4.2 To ensure the normal operation of the instrument using the sensor, it is required to confirm the function of the sensor by exposure to the target gas before each use of the sensor or instrument.

Failure to perform such tests may endanger the safety of people and property.

- 4.3 The sensor contains lead and corrosive liquid, please do not open the case or penetrate the permeable membrane, do not touch the damaged sensor without protective gloves, in case of leakage, avoid contact with eyes.
- 4.4 The sensor is not suited for use in a magnetic resonance imaging (MRI) environment.
- 4.5 Do not use this product for applications that may cause personal injury (including death). Do not use this product for products other than the intended use and authorized use.
- 4.6 Please consult the data sheet and product manual carefully. Failure to follow these instructions may result in death or serious injury.
- 4.7 For any application using this product, expressly reject any responsibilities, including but not limited to consequential or incidental compensation.