

SSD1305

Advance Information

132 x 64 Dot Matrix OLED/PLED Segment/Common Driver with Controller

This document contains information on a new product. Specifications and information herein are subject to change without notice.

<http://www.solomon-systech.com>

SSD1305

Rev 1.8

P 1/71

Jul 2007

Copyright © 2007 Solomon Systech Limited



CONTENTS

1	GENERAL DESCRIPTION	7
2	FEATURES	7
3	ORDERING INFORMATION	7
4	BLOCK DIAGRAM	8
5	DIE PAD FLOOR PLAN	9
6	PIN ARRANGEMENT	12
6.1	SSD1305T6R1 PIN ASSIGNMENT.....	12
6.2	SSD1305T7R1 PIN ASSIGNMENT.....	14
7	PIN DESCRIPTION	16
8	FUNCTIONAL BLOCK DESCRIPTIONS	18
8.1	MCU INTERFACE SELECTION.....	18
8.1.1	MCU Parallel 6800-series Interface.....	18
8.1.2	MCU Parallel 8080-series Interface.....	19
8.1.3	MCU Serial Interface.....	21
8.1.4	MCU I ² C Interface.....	21
8.2	COMMAND DECODER	24
8.3	OSCILLATOR CIRCUIT AND DISPLAY TIME GENERATOR.....	25
8.4	FR SYNCHRONIZATION	26
8.5	RESET CIRCUIT	26
8.6	SEGMENT DRIVERS / COMMON DRIVERS	27
8.7	GRAPHIC DISPLAY DATA RAM (GDDRAM).....	29
8.8	AREA COLOR DECODER.....	30
8.9	SEG/COM DRIVING BLOCK	31
8.10	POWER ON AND OFF SEQUENCE	32
8.11	DC-DC CONVERTER	33
9	COMMAND TABLE	35
9.1	DATA READ / WRITE	41
10	COMMAND DESCRIPTIONS	42
10.1	FUNDAMENTAL COMMAND	42
10.1.1	Set Lower Column Start Address for Page Addressing Mode (00h~0Fh)	42
10.1.2	Set Higher Column Start Address for Page Addressing Mode (10h~1Fh)	42
10.1.3	Set Memory Addressing Mode (20h).....	42
10.1.4	Set Column Address (21h)	43
10.1.5	Set Page Address (22h).....	44
10.1.6	Set Display Start Line (40h~7Fh).....	45
10.1.7	Set Contrast Control for BANK0 (81h).....	45
10.1.8	Set Brightness for Area Color Banks (82h).....	45
10.1.9	Set Look Up Table (LUT) (91h).....	45
10.1.10	Set Bank Color of BANK1 to BANK16 (PAGE0) (92h)	46
10.1.11	Set Bank Color of BANK17 to BANK32 (PAGE0) (93h)	46
10.1.12	Set Segment Re-map (A0h/A1h).....	46
10.1.13	Entire Display ON (A4h/A5h).....	46
10.1.14	Set Normal/Inverse Display (A6h/A7h).....	46
10.1.15	Set Multiplex Ratio (A8h).....	46
10.1.16	Reserved (AAh)	46
10.1.17	Dim Mode setting (ABh)	46

10.1.18	Master Configuration (ADh).....	46
10.1.19	Set Display ON/OFF (ACh/AEh/AFh).....	47
10.1.20	Set Page Start Address for Page Addressing Mode (B0h~B7h).....	47
10.1.21	Set COM Output Scan Direction (C0h/C8h).....	47
10.1.22	Set Display Offset (D3h).....	47
10.1.23	Set Display Clock Divide Ratio/ Oscillator Frequency (D5h).....	50
10.1.24	Set Area Color Mode ON/OFF & Low Power Display Mode (D8h).....	50
10.1.25	Set Pre-charge Period (D9h).....	50
10.1.26	Set COM Pins Hardware Configuration (DAh).....	51
10.1.27	Set V _{COMH} Deselect Level (DBh).....	53
10.1.28	Enter Read Modify Write (E0h).....	53
10.1.29	NOP (E3h).....	54
10.1.30	Exit Read Modify Write (EEh).....	54
10.1.31	Status register Read.....	54
10.2	GRAPHIC ACCELERATION COMMAND.....	55
10.2.1	Horizontal Scroll Setup (26h/27h).....	55
10.2.2	Continuous Vertical and Horizontal Scroll Setup (29h/2Ah).....	56
10.2.3	Deactivate Scroll (2Eh).....	57
10.2.4	Activate Scroll (2Fh).....	57
10.2.5	Set Vertical Scroll Area(A3h).....	58
11	MAXIMUM RATINGS.....	59
12	DC CHARACTERISTICS.....	60
13	AC CHARACTERISTICS.....	61
14	APPLICATION EXAMPLE.....	66
15	PACKAGE INFORMATION.....	67
15.1	SSD1305Z DIE TRAY INFORMATION.....	67
15.2	SSD1305T6R1 DETAIL DIMENSION.....	68
15.3	SSD1305T7R1 DETAIL DIMENSION.....	70

TABLES

TABLE 3-1 : ORDERING INFORMATION	7
TABLE 5-1 : SSD1305Z BUMP DIE PAD COORDINATES	11
TABLE 6-1 : SSD1305T6R1 PIN ASSIGNMENT TABLE	13
TABLE 6-2 : SSD1305T7R1 PIN ASSIGNMENT	15
TABLE 7-1 : PIN DESCRIPTION	16
TABLE 7-2 : MCU BUS INTERFACE PIN SELECTION	17
TABLE 8-1 : MCU INTERFACE ASSIGNMENT UNDER DIFFERENT BUS INTERFACE MODE.....	18
TABLE 8-2 : CONTROL PINS OF 6800 INTERFACE	18
TABLE 8-3 : CONTROL PINS OF 8080 INTERFACE (FORM 1)	20
TABLE 8-4 : CONTROL PINS OF 8080 INTERFACE (FORM 2)	20
TABLE 8-5 : CONTROL PINS OF SERIAL INTERFACE	21
TABLE 8-6 : PASSIVE COMPONENT SELECTION	34
TABLE 9-1: COMMAND TABLE	35
TABLE 9-2 : READ COMMAND TABLE	41
TABLE 9-3 : ADDRESS INCREMENT TABLE (AUTOMATIC).....	41
TABLE 10-1 : EXAMPLE OF SET DISPLAY OFFSET AND DISPLAY START LINE WITH NO REMAP	48
TABLE 10-2 :EXAMPLE OF SET DISPLAY OFFSET AND DISPLAY START LINE WITH REMAP	49
TABLE 10-3 : COM PINS HARDWARE CONFIGURATION.....	51
TABLE 10-4 : EXAMPLE OF READ MODIFY WRITE MODE	54
TABLE 11-1 : MAXIMUM RATINGS (VOLTAGE REFERENCED TO V _{SS})	59
TABLE 12-1 : DC CHARACTERISTICS	60
TABLE 13-1 : AC CHARACTERISTICS	61
TABLE 13-2 : 6800-SERIES MCU PARALLEL INTERFACE TIMING CHARACTERISTICS	62
TABLE 13-3 : 8080-SERIES MCU PARALLEL INTERFACE TIMING CHARACTERISTICS.....	63
TABLE 13-4 : SERIAL INTERFACE TIMING CHARACTERISTICS	64
TABLE 13-5 : I ² C INTERFACE TIMING CHARACTERISTICS	65

FIGURES

FIGURE 4-1 : SSD1305 BLOCK DIAGRAM.....	8
FIGURE 5-1 : SSD1305Z DIE DRAWING.....	9
FIGURE 5-2 : SSD1305Z ALIGNMENT MARKS DIMENSION.....	10
FIGURE 6-1 : SSD1305T6R1 PIN ASSIGNMENT	12
FIGURE 6-2 : SSD1305T7R1 PIN ASSIGNMENT	14
FIGURE 8-1 : DATA READ BACK PROCEDURE - INSERTION OF DUMMY READ.....	19
FIGURE 8-2 : EXAMPLE OF WRITE PROCEDURE IN 8080 PARALLEL INTERFACE MODE.....	19
FIGURE 8-3 : EXAMPLE OF READ PROCEDURE IN 8080 PARALLEL INTERFACE MODE.....	19
FIGURE 8-4 : DISPLAY DATA READ BACK PROCEDURE - INSERTION OF DUMMY READ	20
FIGURE 8-5 : WRITE PROCEDURE IN SPI MODE.....	21
FIGURE 8-6 : I2C-BUS DATA FORMAT.....	22
FIGURE 8-7 : DEFINITION OF THE START AND STOP CONDITION.....	23
FIGURE 8-8 : DEFINITION OF THE ACKNOWLEDGEMENT CONDITION.....	24
FIGURE 8-9 : DEFINITION OF THE DATA TRANSFER CONDITION	24
FIGURE 8-10 : OSCILLATOR CIRCUIT AND DISPLAY TIME GENERATOR	25
FIGURE 8-11 : SEGMENT OUTPUT WAVEFORM IN THREE PHASES.....	27
FIGURE 8-12 : SEGMENT OUTPUT WAVEFORM FOR TWO DIFFERENT COLORS LUT SETTING.....	27
FIGURE 8-13 : EXAMPLE OF SEGMENT OUTPUT WAVEFORM OF MONOCHROME DISPLAY SECTION UNDER MONOCHROME MODE.....	28
FIGURE 8-14 : EXAMPLE OF SEGMENT OUTPUT WAVEFORM OF AREA COLOR DISPLAY SECTION UNDER AREA COLOR MODE.....	28
FIGURE 8-15 : GDDRAM PAGES STRUCTURE OF SSD1305	29
FIGURE 8-16 : ENLARGEMENT OF GDDRAM (NO ROW RE-MAPPING AND COLUMN-RE-MAPPING)	29
FIGURE 8-17 : EXAMPLE OF AREA COLOR ASSIGNMENT ON A 132X64 OLED PANEL	30
FIGURE 8-18 : I _{REF} CURRENT SETTING BY RESISTOR VALUE	31
FIGURE 8-19 : THE POWER ON SEQUENCE.....	32
FIGURE 8-20 : THE POWER OFF SEQUENCE	32
FIGURE 8-21 : DC-DC VOLTAGE CONVERTER CIRCUIT	33
FIGURE 10-1 : ADDRESS POINTER MOVEMENT OF PAGE ADDRESSING MODE	42
FIGURE 10-2 : EXAMPLE OF GDDRAM ACCESS POINTER SETTING IN PAGE ADDRESSING MODE (NO ROW AND COLUMN-RE-MAPPING)	42
FIGURE 10-3 : ADDRESS POINTER MOVEMENT OF HORIZONTAL ADDRESSING MODE.....	43
FIGURE 10-4 : ADDRESS POINTER MOVEMENT OF VERTICAL ADDRESSING MODE	43
FIGURE 10-5 : EXAMPLE OF COLUMN AND ROW ADDRESS POINTER MOVEMENT.....	44
FIGURE 10-6 : SEGMENT CURRENT VS CONTRAST SETTING	45
FIGURE 10-7 : TRANSITION BETWEEN DIFFERENT MODES	47
FIGURE 10-8 : TYPICAL OSCILLATOR FREQUENCY ADJUSTMENT BY D5 COMMAND (V _{DD} =2.8V).....	50
FIGURE 10-9 : HORIZONTAL SCROLL EXAMPLE: SCROLL RIGHT BY 4 COLUMNS	55
FIGURE 10-10 : HORIZONTAL SCROLL EXAMPLE: SCROLL LEFT BY 2 COLUMNS	55
FIGURE 10-11 : HORIZONTAL SCROLLING SETUP EXAMPLE	55
FIGURE 10-12 : CONTINUOUS VERTICAL AND HORIZONTAL SCROLLING SETUP EXAMPLES.....	56
FIGURE 10-13 : CONTINUOUS VERTICAL AND HORIZONTAL SCROLLING EXAMPLE: WITH SETTING IN MUX RATIO	57
FIGURE 10-14 : VERTICAL SCROLL AREA SETUP EXAMPLES	58
FIGURE 13-1 : 6800-SERIES MCU PARALLEL INTERFACE CHARACTERISTICS	62
FIGURE 13-2 : 8080-SERIES PARALLEL INTERFACE CHARACTERISTICS (FORM 1)	63
FIGURE 13-3 : 8080-SERIES PARALLEL INTERFACE CHARACTERISTICS (FORM 2)	63
FIGURE 13-4 : SERIAL INTERFACE CHARACTERISTICS	64
FIGURE 13-5 : I ² C INTERFACE TIMING CHARACTERISTICS	65

FIGURE 14-1 : APPLICATION EXAMPLE OF SSD1305T6R1	66
FIGURE 15-1 SSD1305Z DIE TRAY INFORMATION	67
FIGURE 15-2 SSD1305T6R1 DETAIL DIMENSION	68
FIGURE 15-3 SSD1305T7R1 DETAIL DIMENSION	70

1 GENERAL DESCRIPTION

The SSD1305 is a CMOS OLED/PLED driver with controller for organic/polymer light emitting diode dot-matrix graphic display system. It consists of 132 segments and 64 commons that can support a maximum display resolution of 132x64. There are 4-color selections to support monochrome or area color OLED/PLED. This IC is designed for Common Cathode type OLED panel.

The SSD1305 embeds with contrast control, display RAM and oscillator, which reduces the number of external components and power consumption. It has 256-step brightness control and separate power for I/O interface logic. It is suitable for many compact portable applications, such as mobile phone sub-display, calculator and MP3 player, etc.

2 FEATURES

- Resolution: 132 x 64 dot matrix panel
- Area color support with 4 Color Selection and 64 steps per color
- Power supply:
 - $V_{DD} = 2.4V$ to $3.5V$ for IC logic
 - $V_{CC} = 7.0V$ to $15.0V$ for Panel driving
 - $V_{DDIO} = 1.6V$ to V_{DD} for MCU interface
- Segment maximum source current: 320uA
- Common maximum sink current: 45mA
- Embedded 132 x 64 bit SRAM display buffer
- 256-step Contrast Control
- 8-bit 6800-series Parallel Interface, 8-bit 8080-series Parallel Interface, Serial Peripheral Interface, I²C Interface
- Row Re-mapping and Column Re-mapping
- Continuous Horizontal, Vertical and Diagonal Scrolling
- Dim Mode operations
- Programmable Frame Frequency and Multiplexing Ratio
- On-Chip Oscillator
- DC-DC Controller embedded
- Low power consumption
- Wide range of operating temperatures: -40 to 85 °C

3 ORDERING INFORMATION

Table 3-1 : Ordering Information

Ordering Part Number	SEG	COM	Package Form	Reference	Remark
SSD1305Z	132	64	Gold Bump Die	Page 9, 67	<ul style="list-style-type: none"> • Min SEG pad pitch: 52um • Min COM pad pitch: 45um
SSD1305T6R1	132	64	TAB	Page 12 ,68	<ul style="list-style-type: none"> • 35mm film, 4 sprocket hole • Folding TAB • 8-bit 80 / 8-bit 68 / SPI / I²C interface • SEG lead pitch 0.120mm x 0.998 =0.11976mm • COM lead pitch 0.120mm x 0.998 =0.11976mm
SSD1305T7R1	132	64	TAB	Page 14, 70	<ul style="list-style-type: none"> • 35mm film, 4 sprocket hole • Folding TAB • 8-bit 80 / 8-bit 68 / SPI / I²C interface • SEG lead pitch 0.120mm x 0.998 =0.11976mm • COM lead pitch 0.120mm x 0.998 =0.11976mm

4 BLOCK DIAGRAM

Figure 4-1 : SSD1305 Block Diagram

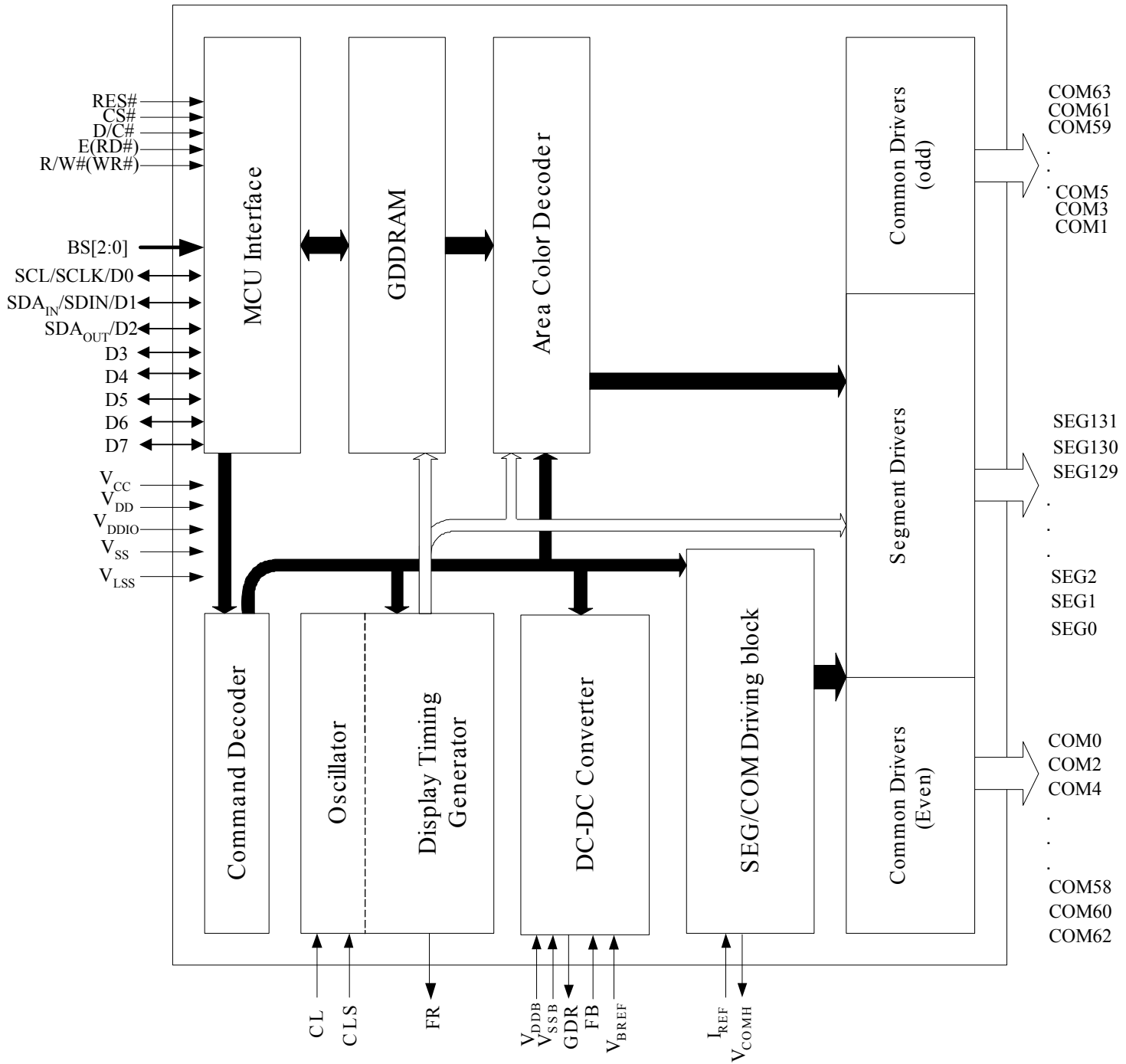

5 DIE PAD FLOOR PLAN

Figure 5-1 : SSD1305Z Die Drawing

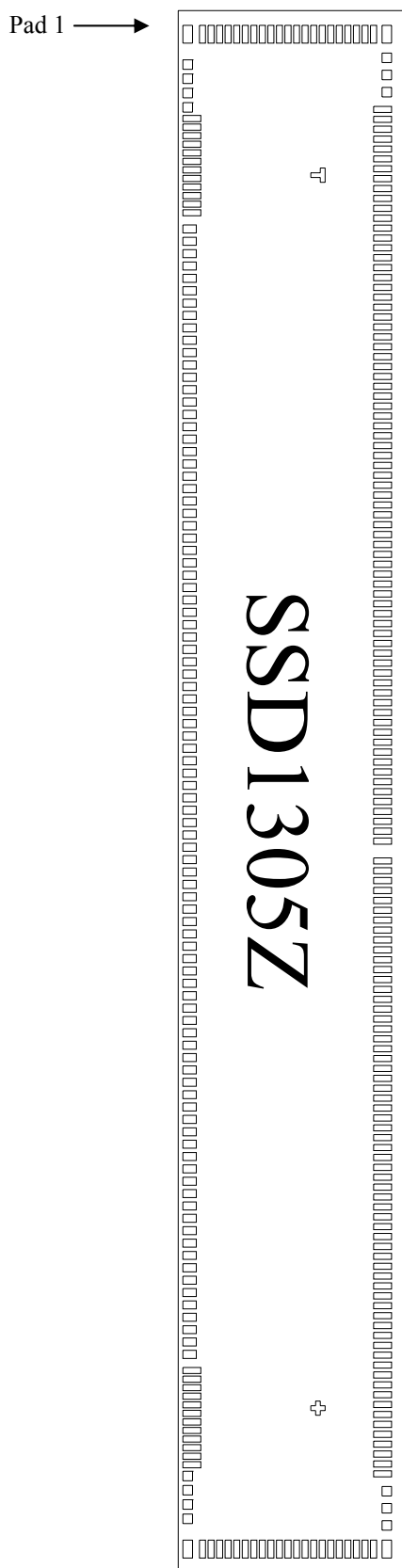

Alignment marks

(For details dimension please see p.9)

	Position	Size
T shape	(-3240, 139)	75um x 75um
+ shape	(3240, 139)	75um x 75um

Die Size	8.2mm x 1.2mm
Die Thickness	457 um ± 25 um
Min I/O pad pitch	65 um
Min SEG pad pitch	52 um
Min COM pad pitch	45 um
Bump Height	Nominal 15 um

Bump Size		
Pad #	X [um]	Y [um]
1, 126, 148, 293	94	50
18-109	42	70
2-5, 122-125, 149-151, 290-292	50	50
6-17, 110-121, 152-289	32	94
127-147, 294-314	94	32

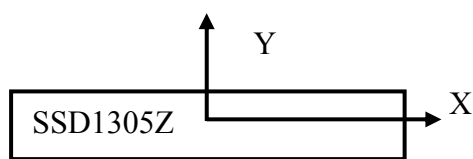

Pad 1,2,3,...->126
Gold Bumps face up

Figure 5-2 : SSD1305Z Alignment Marks Dimension

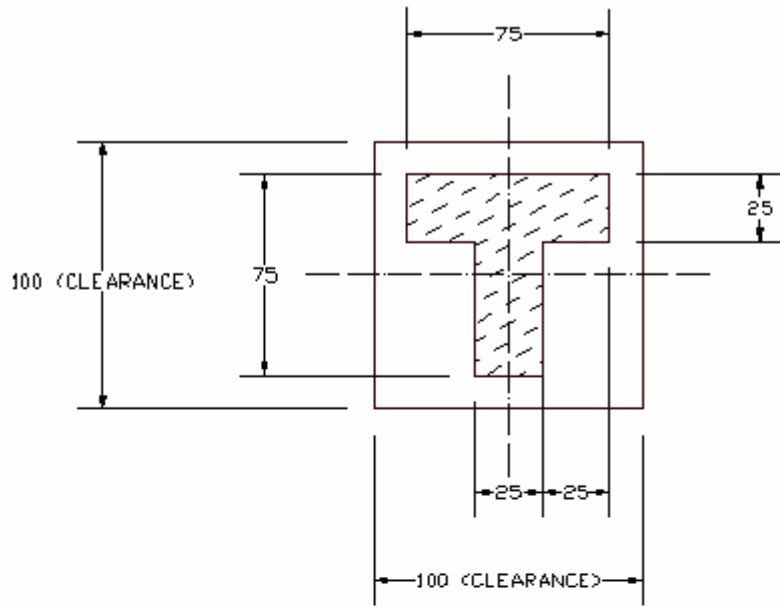

T shape

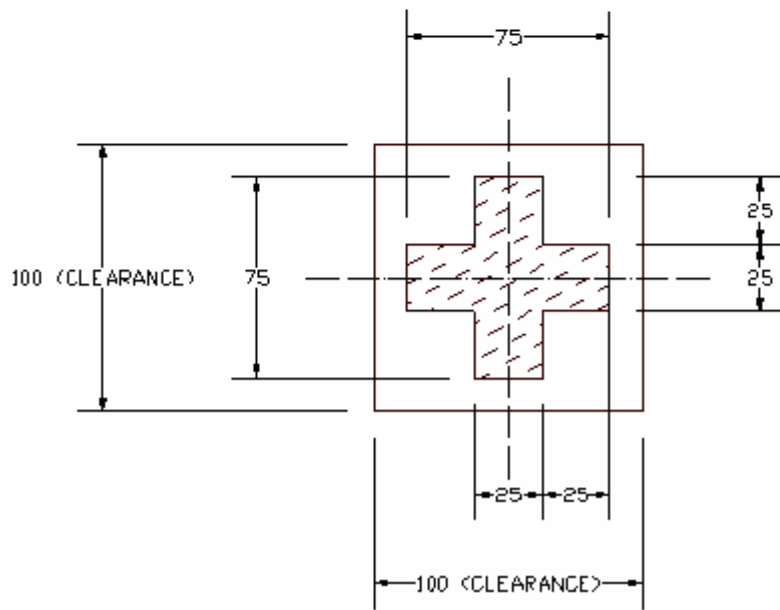

+ shape

Unit in um

Table 5-1 : SSD1305Z Bump Die Pad Coordinates

Pad no.	Pad Name	X-pos	Y-pos	Pad no.	Pad Name	X-pos	Y-pos	Pad no.	Pad Name	X-pos	Y-pos	Pad no.	Pad Name	X-pos	Y-pos
1	NC	-3980.5	-546.0	81	VDDIO	1137.5	-536.0	161	SEG6	3117.6	479.1	241	SEG86	-1091.2	479.1
2	NC	-3821.5	-546.0	82	D0	1202.5	-536.0	162	SEG7	3065.7	479.1	242	SEG87	-1143.1	479.1
3	NC	-3746.5	-546.0	83	D1	1267.5	-536.0	163	SEG8	3013.7	479.1	243	SEG88	-1195.1	479.1
4	NC	-3671.5	-546.0	84	D2	1332.5	-536.0	164	SEG9	2961.7	479.1	244	SEG89	-1247.0	479.1
5	NC	-3596.5	-546.0	85	D3	1397.5	-536.0	165	SEG10	2909.8	479.1	245	SEG90	-1299.0	479.1
6	COM53	-3537.5	-524.0	86	VSS	1462.5	-536.0	166	SEG11	2857.8	479.1	246	SEG91	-1351.0	479.1
7	COM54	-3492.5	-524.0	87	D4	1527.5	-536.0	167	SEG12	2805.9	479.1	247	SEG92	-1402.9	479.1
8	COM55	-3447.5	-524.0	88	D5	1592.5	-536.0	168	SEG13	2753.9	479.1	248	SEG93	-1454.9	479.1
9	COM56	-3402.5	-524.0	89	D6	1657.5	-536.0	169	SEG14	2701.9	479.1	249	SEG94	-1506.8	479.1
10	COM57	-3357.5	-524.0	90	D7	1722.5	-536.0	170	SEG15	2650.0	479.1	250	SEG95	-1558.8	479.1
11	COM58	-3312.5	-524.0	91	VSS	1787.5	-536.0	171	SEG16	2598.0	479.1	251	SEG96	-1610.8	479.1
12	COM59	-3267.5	-524.0	92	CLS	1852.5	-536.0	172	SEG17	2546.1	479.1	252	SEG97	-1662.7	479.1
13	COM60	-3222.5	-524.0	93	VDDIO	1917.5	-536.0	173	SEG18	2494.1	479.1	253	SEG98	-1714.7	479.1
14	COM61	-3177.5	-524.0	94	VDDIO	1982.5	-536.0	174	SEG19	2442.1	479.1	254	SEG99	-1766.6	479.1
15	COM62	-3132.5	-524.0	95	VDD	2047.5	-536.0	175	SEG20	2390.2	479.1	255	SEG100	-1818.6	479.1
16	COM63	-3087.5	-524.0	96	VDD	2112.5	-536.0	176	SEG21	2338.2	479.1	256	SEG101	-1870.6	479.1
17	NC	-3042.5	-524.0	97	VDD	2177.5	-536.0	177	SEG22	2286.3	479.1	257	SEG102	-1922.5	479.1
18	NC	-2957.5	-536.0	98	IREF	2242.5	-536.0	178	SEG23	2234.3	479.1	258	SEG103	-1974.5	479.1
19	VCC	-2892.5	-536.0	99	VCOMH	2307.5	-536.0	179	SEG24	2182.3	479.1	259	SEG104	-2026.4	479.1
20	VCC	-2827.5	-536.0	100	VCC	2372.5	-536.0	180	SEG25	2130.4	479.1	260	SEG105	-2078.4	479.1
21	VCC	-2762.5	-536.0	101	VCC	2437.5	-536.0	181	SEG26	2078.4	479.1	261	SEG106	-2130.4	479.1
22	VCOMH	-2697.5	-536.0	102	VCC	2502.5	-536.0	182	SEG27	2026.5	479.1	262	SEG107	-2182.3	479.1
23	VLSS	-2632.5	-536.0	103	VCC	2567.5	-536.0	183	SEG28	1974.5	479.1	263	SEG108	-2234.3	479.1
24	VLSS	-2567.5	-536.0	104	VCC	2632.5	-536.0	184	SEG29	1922.5	479.1	264	SEG109	-2286.2	479.1
25	VLSS	-2502.5	-536.0	105	VCC	2697.5	-536.0	185	SEG30	1870.6	479.1	265	SEG110	-2338.2	479.1
26	VSS	-2437.5	-536.0	106	VLSS	2762.5	-536.0	186	SEG31	1818.6	479.1	266	SEG111	-2390.2	479.1
27	VSS	-2372.5	-536.0	107	VLSS	2827.5	-536.0	187	SEG32	1766.7	479.1	267	SEG112	-2442.1	479.1
28	TR11	-2307.5	-536.0	108	VLSS	2892.5	-536.0	188	SEG33	1714.7	479.1	268	SEG113	-2494.1	479.1
29	TR10	-2242.5	-536.0	109	NC	2957.5	-536.0	189	SEG34	1662.7	479.1	269	SEG114	-2546.0	479.1
30	TR9	-2177.5	-536.0	110	NC	3042.5	-524.0	190	SEG35	1610.8	479.1	270	SEG115	-2598.0	479.1
31	TR8	-2112.5	-536.0	111	COM31	3087.5	-524.0	191	SEG36	1558.8	479.1	271	SEG116	-2650.0	479.1
32	TR7	-2047.5	-536.0	112	COM30	3132.5	-524.0	192	SEG37	1506.9	479.1	272	SEG117	-2701.9	479.1
33	TR6	-1982.5	-536.0	113	COM29	3177.5	-524.0	193	SEG38	1454.9	479.1	273	SEG118	-2753.9	479.1
34	VSS	-1917.5	-536.0	114	COM28	3222.5	-524.0	194	SEG39	1402.9	479.1	274	SEG119	-2805.8	479.1
35	TR5	-1852.5	-536.0	115	COM27	3267.5	-524.0	195	SEG40	1351.0	479.1	275	SEG120	-2857.8	479.1
36	TR4	-1787.5	-536.0	116	COM26	3312.5	-524.0	196	SEG41	1299.0	479.1	276	SEG121	-2909.8	479.1
37	TR3	-1722.5	-536.0	117	COM25	3357.5	-524.0	197	SEG42	1247.1	479.1	277	SEG122	-2961.7	479.1
38	TR2	-1657.5	-536.0	118	COM24	3402.5	-524.0	198	SEG43	1195.1	479.1	278	SEG123	-3013.7	479.1
39	TR1	-1592.5	-536.0	119	COM23	3447.5	-524.0	199	SEG44	1143.1	479.1	279	SEG124	-3065.6	479.1
40	TR0	-1527.5	-536.0	120	COM22	3492.5	-524.0	200	SEG45	1091.2	479.1	280	SEG125	-3117.6	479.1
41	VSS	-1462.5	-536.0	121	COM21	3537.5	-524.0	201	SEG46	1039.2	479.1	281	SEG126	-3169.6	479.1
42	VSSB	-1397.5	-536.0	122	NC	3596.5	-546.0	202	SEG47	987.3	479.1	282	SEG127	-3221.5	479.1
43	GDR	-1332.5	-536.0	123	NC	3671.5	-546.0	203	SEG48	935.3	479.1	283	SEG128	-3273.5	479.1
44	GDR	-1267.5	-536.0	124	NC	3746.5	-546.0	204	SEG49	883.3	479.1	284	SEG129	-3325.4	479.1
45	VDDB	-1202.5	-536.0	125	NC	3821.5	-546.0	205	SEG50	831.4	479.1	285	SEG130	-3377.4	479.1
46	VDDB	-1137.5	-536.0	126	NC	3900.5	-546.0	206	SEG51	779.4	479.1	286	SEG131	-3429.4	479.1
47	VDDB	-1072.5	-536.0	127	COM20	3980.5	-468.4	207	SEG52	727.5	479.1	287	NC	-3481.3	479.1
48	FB	-1007.5	-536.0	128	COM19	3980.5	-423.4	208	SEG53	675.5	479.1	288	NC	-3533.3	479.1
49	VBREF	-942.5	-536.0	129	COM18	3980.5	-378.4	209	SEG54	623.5	479.1	289	NC	-3585.2	479.1
50	BGGND	-877.5	-536.0	130	COM17	3980.5	-333.4	210	SEG55	571.6	479.1	290	NC	-3637.2	501.1
51	VSS	-812.5	-536.0	131	COM16	3980.5	-288.4	211	SEG56	519.6	479.1	291	NC	-3689.2	501.1
52	VDDB	-747.5	-536.0	132	COM15	3980.5	-243.4	212	SEG57	467.7	479.1	292	NC	-3741.2	501.1
53	VCIR	-682.5	-536.0	133	COM14	3980.5	-198.4	213	SEG58	415.7	479.1	293	NC	-3793.2	501.1
54	VCIR	-617.5	-536.0	134	COM13	3980.5	-153.4	214	SEG59	363.7	479.1	294	COM32	-3980.5	431.6
55	VDD	-552.5	-536.0	135	COM12	3980.5	-108.4	215	SEG60	259.8	479.1	295	COM33	-3980.5	386.6
56	VDD	-487.5	-536.0	136	COM11	3980.5	-63.4	216	SEG61	207.9	479.1	296	COM34	-3980.5	341.6
57	VDD	-422.5	-536.0	137	COM10	3980.5	-18.4	217	SEG62	155.9	479.1	297	COM35	-3980.5	296.6
58	VDD	-357.5	-536.0	138	COM9	3980.5	26.6	218	SEG63	103.9	479.1	298	COM36	-3980.5	251.6
59	VDDIO	-292.5	-536.0	139	COM8	3980.5	71.6	219	SEG64	52.0	479.1	299	COM37	-3980.5	206.6
60	VDDIO	-227.5	-536.0	140	COM7	3980.5	116.6	220	SEG65	0.0	479.1	300	COM38	-3980.5	161.6
61	VDDIO	-162.5	-536.0	141	COM6	3980.5	161.6	221	SEG66	-52.0	479.1	301	COM39	-3980.5	116.6
62	VCC	-97.5	-536.0	142	COM5	3980.5	206.6	222	SEG67	-103.9	479.1	302	COM40	-3980.5	71.6
63	VCC	-32.5	-536.0	143	COM4	3980.5	251.6	223	SEG68	-155.9	479.1	303	COM41	-3980.5	26.6
64	VCC	32.5	-536.0	144	COM3	3980.5	296.6	224	SEG69	-207.8	479.1	304	COM42	-3980.5	-18.4
65	VDDIO	97.5	-536.0	145	COM2	3980.5	341.6	225	SEG70	-259.8	479.1	305	COM43	-3980.5	-63.4
66	B50	162.5	-536.0	146	COM1	3980.5	386.6	226	SEG71	-311.8	479.1	306	COM44	-3980.5	-108.4
67	VSS	227.5	-536.0	147	COM0	3980.5	431.6	227	SEG72	-363.7	479.1	307	COM45	-3980.5	-153.4
68	BS1	292.5	-536.0	148	NC	3980.5	501.1	228	SEG73	-415.7	479.1	308	COM46	-3980.5	-198.4
69	VDDIO	357.5	-536.0	149	NC	3856.5	501.1	229	SEG74	-467.6	479.1	309	COM47	-3980.5	-243.4
70	BS2	422.5	-536.0	150	NC	3766.5	501.1	230	SEG75	-519.6	479.1	310	COM48	-3980.5	-288.4
71	VSS	487.5	-536.0	151	NC	3676.5	501.1	231	SEG76	-571.6	479.1	311	COM49	-3980.5	-333.4
72	FR	552.5	-536.0	152	NC	3585.2	479.1	232	SEG77	-623.5	479.1	312	COM50	-3980.5	-378.4
73	CL	617.5	-536.0	153	NC	3533.3	479.1	233	SEG78	-675.5	479.1	313	COM51	-3980.5	-423.4
74	VSS	682.5	-536.0	154	NC	3481.3	479.1	234	SEG79	-727.4	479.1	314	COM52	-3980.5	-468.4
75	CS#	747.5	-536.0	155	SEG0	3429.4	479.1	235	SEG80	-779.4	479.1				
76	RES#	812.5	-536.0	156	SEG1	3377.4	479.1	236	SEG81	-831.4	479.1				
77	D/C#	877.5	-536.0	157	SEG2	3325.4	479.1	237	SEG82	-883.3	479.1				
78	VSS	942.5	-536.0	158	SEG3	3273.5	479.1	238	SEG83	-935.3	479.1				
79	R/W#(WR#)	1007.5	-536.0	159	SEG4	3221.5	479.1	239	SEG84	-987.2	479.1				
80	E(RD#)	1072.5	-536.0	160	SEG5	3169.6	479.1	240	SEG85	-1039.2	479.1				

6 PIN ARRANGEMENT

6.1 SSD1305T6R1 pin assignment

Figure 6-1 : SSD1305T6R1 Pin Assignment

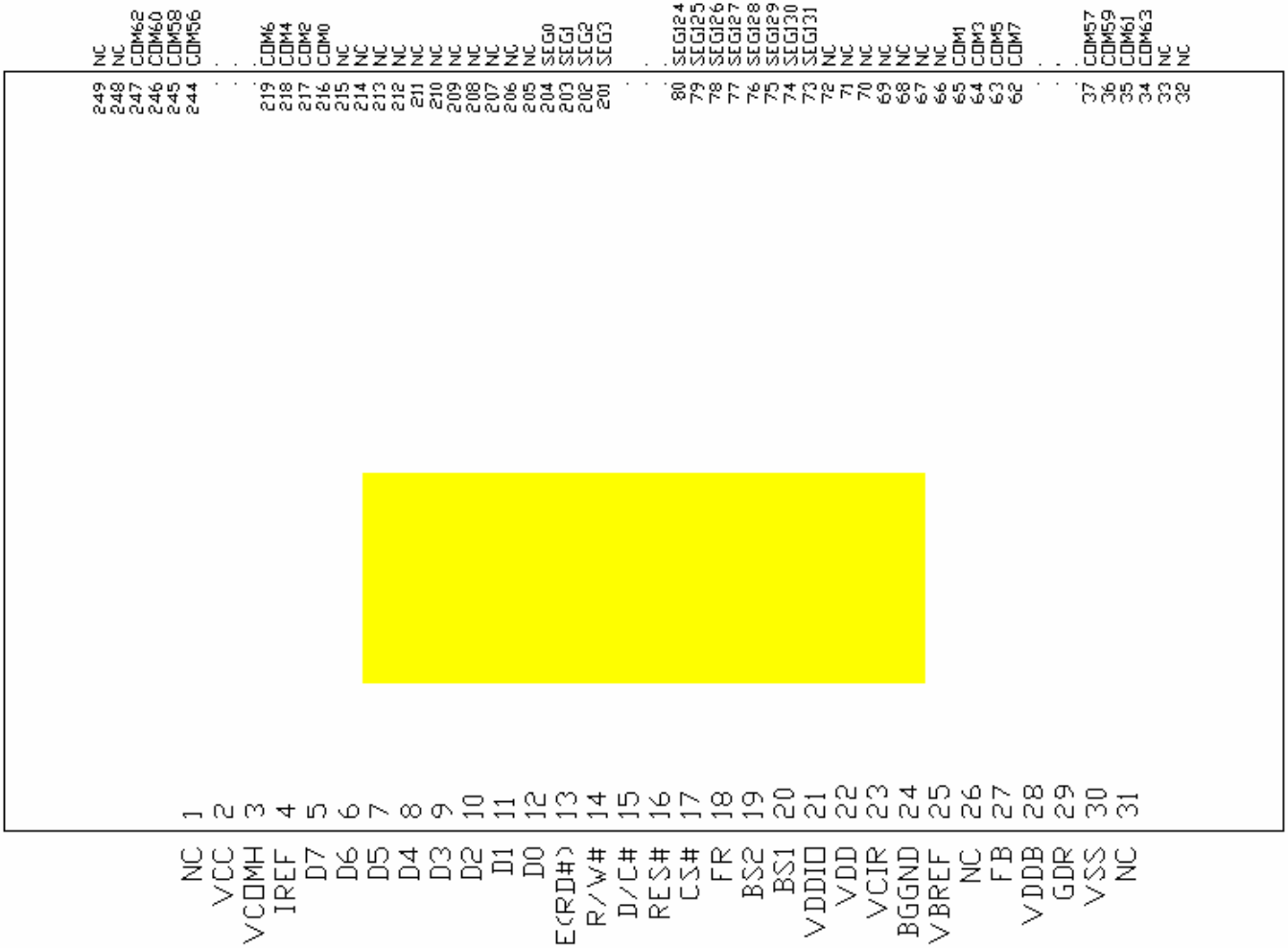

Table 6-1 : SSD1305T6R1 Pin Assignment Table

Pin#	Name	Pin#	Name	Pin#	Name	Pin#	Name
1	NC	81	SEG123	161	SEG43	241	COM50
2	VCC	82	SEG122	162	SEG42	242	COM52
3	VCOMH	83	SEG121	163	SEG41	243	COM54
4	IREF	84	SEG120	164	SEG40	244	COM56
5	D7	85	SEG119	165	SEG39	245	COM58
6	D6	86	SEG118	166	SEG38	246	COM60
7	D5	87	SEG117	167	SEG37	247	COM62
8	D4	88	SEG116	168	SEG36	248	NC
9	D3	89	SEG115	169	SEG35	249	NC
10	D2	90	SEG114	170	SEG34		
11	D1	91	SEG113	171	SEG33		
12	D0	92	SEG112	172	SEG32		
13	E(RD#)	93	SEG111	173	SEG31		
14	R/W#	94	SEG110	174	SEG30		
15	D/C#	95	SEG109	175	SEG29		
16	RES#	96	SEG108	176	SEG28		
17	CS#	97	SEG107	177	SEG27		
18	FR	98	SEG106	178	SEG26		
19	BS2	99	SEG105	179	SEG25		
20	BS1	100	SEG104	180	SEG24		
21	VDDIO	101	SEG103	181	SEG23		
22	VDD	102	SEG102	182	SEG22		
23	VCIR	103	SEG101	183	SEG21		
24	BGGND	104	SEG100	184	SEG20		
25	VBREF	105	SEG99	185	SEG19		
26	NC	106	SEG98	186	SEG18		
27	FB	107	SEG97	187	SEG17		
28	VDDB	108	SEG96	188	SEG16		
29	GDR	109	SEG95	189	SEG15		
30	VSS	110	SEG94	190	SEG14		
31	NC	111	SEG93	191	SEG13		
32	NC	112	SEG92	192	SEG12		
33	NC	113	SEG91	193	SEG11		
34	COM63	114	SEG90	194	SEG10		
35	COM61	115	SEG89	195	SEG9		
36	COM59	116	SEG88	196	SEG8		
37	COM57	117	SEG87	197	SEG7		
38	COM55	118	SEG86	198	SEG6		
39	COM53	119	SEG85	199	SEG5		
40	COM51	120	SEG84	200	SEG4		
41	COM49	121	SEG83	201	SEG3		
42	COM47	122	SEG82	202	SEG2		
43	COM45	123	SEG81	203	SEG1		
44	COM43	124	SEG80	204	SEG0		
45	COM41	125	SEG79	205	NC		
46	COM39	126	SEG78	206	NC		
47	COM37	127	SEG77	207	NC		
48	COM35	128	SEG76	208	NC		
49	COM33	129	SEG75	209	NC		
50	COM31	130	SEG74	210	NC		
51	COM29	131	SEG73	211	NC		
52	COM27	132	SEG72	212	NC		
53	COM25	133	SEG71	213	NC		
54	COM23	134	SEG70	214	NC		
55	COM21	135	SEG69	215	NC		
56	COM19	136	SEG68	216	COM0		
57	COM17	137	SEG67	217	COM2		
58	COM15	138	SEG66	218	COM4		
59	COM13	139	SEG65	219	COM6		
60	COM11	140	SEG64	220	COM8		
61	COM9	141	SEG63	221	COM10		
62	COM7	142	SEG62	222	COM12		
63	COM5	143	SEG61	223	COM14		
64	COM3	144	SEG60	224	COM16		
65	COM1	145	SEG59	225	COM18		
66	NC	146	SEG58	226	COM20		
67	NC	147	SEG57	227	COM22		
68	NC	148	SEG56	228	COM24		
69	NC	149	SEG55	229	COM26		
70	NC	150	SEG54	230	COM28		
71	NC	151	SEG53	231	COM30		
72	NC	152	SEG52	232	COM32		
73	SEG131	153	SEG51	233	COM34		
74	SEG130	154	SEG50	234	COM36		
75	SEG129	155	SEG49	235	COM38		
76	SEG128	156	SEG48	236	COM40		
77	SEG127	157	SEG47	237	COM42		
78	SEG126	158	SEG46	238	COM44		
79	SEG125	159	SEG45	239	COM46		
80	SEG124	160	SEG44	240	COM48		

6.2 SSD1305T7R1 pin assignment

Figure 6-2 : SSD1305T7R1 Pin Assignment

1	NC	249	NC
2	VCC	248	NC
3	VCOMH	247	COM62
4	IREF	246	COM60
5	D7	245	COM58
6	D6	244	COM56
7	D5	219	COM6
8	D4	218	COM4
9	D3	217	COM2
10	D2	216	COM0
11	D1	215	NC
12	D0	214	NC
13	E/RD#	213	NC
14	R/W#	212	NC
15	D/C#	211	NC
16	RES#	210	NC
17	CS#	209	NC
18	NC	208	NC
19	BS2	207	NC
20	BS1	206	NC
21	VDD	205	NC
22	NC	204	SEG0
23	NC	203	SEG1
24	NC	202	SEG2
25	VBREF	201	SEG3
26	NC	80	SEG124
27	FB	79	SEG125
28	VDDDB	78	SEG126
29	GDR	77	SEG127
30	VSS	76	SEG128
31	NC	75	SEG129
		74	SEG130
		73	SEG131
		72	NC
		71	NC
		70	NC
		69	NC
		68	NC
		67	NC
		66	NC
		65	COM1
		64	COM3
		63	COM5
		62	COM7
		37	COM57
		36	COM59
		35	COM61
		34	COM63
		33	NC
		32	NC

Table 6-2 : SSD1305T7R1 Pin Assignment

Pin #	Name	Pin #	Name	Pin #	Name	Pin #	Name
1	NC	81	SEG123	161	SEG43	241	COM50
2	VCC	82	SEG122	162	SEG42	242	COM52
3	VCOMH	83	SEG121	163	SEG41	243	COM54
4	IREF	84	SEG120	164	SEG40	244	COM56
5	D7	85	SEG119	165	SEG39	245	COM58
6	D6	86	SEG118	166	SEG38	246	COM60
7	D5	87	SEG117	167	SEG37	247	COM62
8	D4	88	SEG116	168	SEG36	248	NC
9	D3	89	SEG115	169	SEG35	249	NC
10	D2	90	SEG114	170	SEG34		
11	D1	91	SEG113	171	SEG33		
12	D0	92	SEG112	172	SEG32		
13	E/RD#	93	SEG111	173	SEG31		
14	R/W#	94	SEG110	174	SEG30		
15	D/C#	95	SEG109	175	SEG29		
16	RES#	96	SEG108	176	SEG28		
17	CS#	97	SEG107	177	SEG27		
18	NC	98	SEG106	178	SEG26		
19	BS2	99	SEG105	179	SEG25		
20	BS1	100	SEG104	180	SEG24		
21	VDD	101	SEG103	181	SEG23		
22	NC	102	SEG102	182	SEG22		
23	NC	103	SEG101	183	SEG21		
24	NC	104	SEG100	184	SEG20		
25	VBREF	105	SEG99	185	SEG19		
26	NC	106	SEG98	186	SEG18		
27	FB	107	SEG97	187	SEG17		
28	VDDB	108	SEG96	188	SEG16		
29	GDR	109	SEG95	189	SEG15		
30	VSS	110	SEG94	190	SEG14		
31	NC	111	SEG93	191	SEG13		
32	NC	112	SEG92	192	SEG12		
33	NC	113	SEG91	193	SEG11		
34	COM63	114	SEG90	194	SEG10		
35	COM61	115	SEG89	195	SEG9		
36	COM59	116	SEG88	196	SEG8		
37	COM57	117	SEG87	197	SEG7		
38	COM55	118	SEG86	198	SEG6		
39	COM53	119	SEG85	199	SEG5		
40	COM51	120	SEG84	200	SEG4		
41	COM49	121	SEG83	201	SEG3		
42	COM47	122	SEG82	202	SEG2		
43	COM45	123	SEG81	203	SEG1		
44	COM43	124	SEG80	204	SEG0		
45	COM41	125	SEG79	205	NC		
46	COM39	126	SEG78	206	NC		
47	COM37	127	SEG77	207	NC		
48	COM35	128	SEG76	208	NC		
49	COM33	129	SEG75	209	NC		
50	COM31	130	SEG74	210	NC		
51	COM29	131	SEG73	211	NC		
52	COM27	132	SEG72	212	NC		
53	COM25	133	SEG71	213	NC		
54	COM23	134	SEG70	214	NC		
55	COM21	135	SEG69	215	NC		
56	COM19	136	SEG68	216	COM0		
57	COM17	137	SEG67	217	COM2		
58	COM15	138	SEG66	218	COM4		
59	COM13	139	SEG65	219	COM6		
60	COM11	140	SEG64	220	COM8		
61	COM9	141	SEG63	221	COM10		
62	COM7	142	SEG62	222	COM12		
63	COM5	143	SEG61	223	COM14		
64	COM3	144	SEG60	224	COM16		
65	COM1	145	SEG59	225	COM18		
66	NC	146	SEG58	226	COM20		
67	NC	147	SEG57	227	COM22		
68	NC	148	SEG56	228	COM24		
69	NC	149	SEG55	229	COM26		
70	NC	150	SEG54	230	COM28		
71	NC	151	SEG53	231	COM30		
72	NC	152	SEG52	232	COM32		
73	SEG131	153	SEG51	233	COM34		
74	SEG130	154	SEG50	234	COM36		
75	SEG129	155	SEG49	235	COM38		
76	SEG128	156	SEG48	236	COM40		
77	SEG127	157	SEG47	237	COM42		
78	SEG126	158	SEG46	238	COM44		
79	SEG125	159	SEG45	239	COM46		
80	SEG124	160	SEG44	240	COM48		

7 PIN DESCRIPTION

Key: I = Input, O =Output, IO = Bi-directional (input/output), P = Power pin

Table 7-1 : Pin Description

Pin Name	Pin Type	Description
V _{DD}	P	Power supply pin for core logic operation.
V _{DDIO}	P	Power supply for interface logic level. It should be match with MCU interface voltage level. V _{DDIO} must always be equal or lower than V _{DD} .
V _{CC}	P	Power supply for panel driving voltage. This is also the most positive power voltage supply pin.
V _{SS}	P	This is a ground pin.
V _{LSS}	P	This is an analog ground pin. It should be connected to V _{SS} externally.
V _{COMH}	O	The pin for COM signal deselected voltage level. A capacitor should be connected between this pin and V _{SS} .
BGGND	P	This pin must be connected to ground.
V _{DDB}	P	This is a power supply pin for internal buffer of the DC-DC voltage converter. It must be connected to V _{DD} . Refer to Section 8.11 for DC-DC converter details.
V _{SSB}	P	This is a ground pin for internal buffer of the DC-DC voltage converter. It must be connected to V _{SS} . Refer to Section 8.11 for DC-DC converter details.
GDR	O	This output pin drives the gate of external NMOS in DC-DC circuit. Refer to Section 8.11 for DC-DC converter details. It should be kept NC (i.e. Float during normal operation) when internal DC-DC converter is not used.
FB	I	Feedback resistor input pin for DC-DC circuit. It is used to adjust DC-DC output voltage level, V _{CC} . Refer to Section 8.11 for DC-DC converter details. It should be kept NC (i.e. Float during normal operation) when internal DC-DC converter is not used.
V _{BREF}	P	Internal voltage reference pin for DC-DC circuit. A stabilization capacitor should be connected to ground. Refer to Section 8.11 for DC-DC converter details. It should be kept NC (i.e. Float during normal operation) when internal DC-DC converter is not used.
V _{CIR}	O	This is a reserved pin. It should be kept NC (i.e. Float during normal operation).
BS[2:0]	I	MCU bus interface selection pins. Please refer to Table 7-2 for the details of setting.
I _{REF}	I	This is segment output current reference pin. A resistor should be connected between this pin and V _{SS} to maintain the I _{REF} current at 10uA. Please refer to Figure 8-18 for the details of resistor value.
FR	O	This pin outputs RAM write synchronization signal. Proper timing between MCU data writing and frame display timing can be achieved to prevent tearing effect. It should be kept NC if it is not used. Please refer to Section 8.4 for details usage.
CL	I	This is external clock input pin. When internal clock is enabled (i.e. HIGH in CLS pin), this pin is not used and should be connected to V _{SS} . When internal clock is disabled (i.e. LOW in CLS pin), this pin is the external clock source input pin.

Pin Name	Pin Type	Description
CLS	I	This is internal clock enable pin. When it is pulled HIGH (i.e. connect to V _{DDIO}), internal clock is enabled. When it is pulled LOW, the internal clock is disabled; an external clock source must be connected to the CL pin for normal operation.
RES#	I	This pin is reset signal input. When the pin is LOW, initialization of the chip is executed. Keep this pin HIGH (i.e. connect to V _{DDIO}) during normal operation.
CS#	I	This pin is the chip select input. (active LOW)
D/C#	I	This is Data/Command control pin. When it is pulled HIGH (i.e. connect to V _{DDIO}), the data at D[7:0] is treated as data. When it is pulled LOW, the data at D[7:0] will be transferred to the command register. In I ² C mode, this pin acts as SA0 for slave address selection. For detail relationship to MCU interface signals, please refer to the Timing Characteristics Diagrams: Figure 13-1 to Figure 13-5.
E (RD#)	I	When interfacing to a 6800-series microprocessor, this pin will be used as the Enable (E) signal. Read/write operation is initiated when this pin is pulled HIGH (i.e. connect to V _{DDIO}) and the chip is selected. When connecting to an 8080-microprocessor, this pin receives the Read (RD#) signal. Read operation is initiated when this pin is pulled LOW and the chip is selected. When serial interface is selected, this pin must be connected to V _{SS} .
R/W#(WR#)	I	This is read / write control input pin connecting to the MCU interface. When interfacing to a 6800-series microprocessor, this pin will be used as Read/Write (R/W#) selection input. Read mode will be carried out when this pin is pulled HIGH (i.e. connect to V _{DDIO}) and write mode when LOW. When 8080 interface mode is selected, this pin will be the Write (WR#) input. Data write operation is initiated when this pin is pulled LOW and the chip is selected. When serial interface is selected, this pin must be connected to V _{SS} .
D[7:0]	IO	These are 8-bit bi-directional data bus to be connected to the microprocessor's data bus. When serial interface mode is selected, D0 will be the serial clock input: SCLK; D1 will be the serial data input: SDIN and D2 should be left opened. When I ² C mode is selected, D2, D1 should be tied together and serve as SDA _{out} , SDA _{in} in application and D0 is the serial clock input, SCL.
TR0-TR11	-	Testing reserved pins. It should be kept NC.
SEG0 ~ SEG131	O	These pins provide Segment switch signals to OLED panel. They are in high impedance stage when display is OFF.
COM0 ~ COM63	O	These pins provide Common switch signals to OLED panel. They are in high impedance state when display is OFF.
NC	-	This is dummy pin. Do not group or short NC pins together.

Table 7-2 : MCU Bus Interface Pin Selection

Pin Name	I ² C Interface	6800-parallel interface (8 bit)	8080-parallel interface (8 bit)	Serial interface
BS0	0	0	0	0
BS1	1	0	1	0
BS2	0	1	1	0

Note

⁽¹⁾ 0 is connected to V_{SS}

⁽²⁾ 1 is connected to V_{DDIO}

8 FUNCTIONAL BLOCK DESCRIPTIONS

8.1 MCU Interface selection

SSD1305 MCU interface consist of 8 data pins and 5 control pins. The pin assignment at different interface mode is summarized in Table 8-1. Different MCU mode can be set by hardware selection on BS[2:0] pins (please refer to Table 7-2 for BS[2:0] setting).

Table 8-1 : MCU interface assignment under different bus interface mode

Pin Name Bus Interface	Data/Command Interface								Control Signal				
	D7	D6	D5	D4	D3	D2	D1	D0	E	R/W#	CS#	D/C#	RES#
8-bit 8080	D[7:0]								RD#	WR#	CS#	D/C#	RES#
8-bit 6800	D[7:0]								E	R/W#	CS#	D/C#	RES#
SPI	Tie LOW				NC	SDIN	SCLK	Tie LOW		CS#	D/C#	RES#	
I ² C	Tie LOW				SDA _{OUT}	SDA _{IN}	SCL	Tie LOW		SA0	RES#		

8.1.1 MCU Parallel 6800-series Interface

The parallel interface consists of 8 bi-directional data pins (D[7:0]), R/W#, D/C#, E and CS#.

A LOW in R/W# indicates WRITE operation and HIGH in R/W# indicates READ operation.

A LOW in D/C# indicates COMMAND read/write and HIGH in D/C# indicates DATA read/write.

The E input serves as data latch signal while CS# is LOW. Data is latched at the falling edge of E signal.

Table 8-2 : Control pins of 6800 interface

Function	E	R/W#	CS#	D/C#
Write command	↓	L	L	L
Read status	↓	H	L	L
Write data	↓	L	L	H
Read data	↓	H	L	H

Note

⁽¹⁾ ↓ stands for falling edge of signal

H stands for HIGH in signal

L stands for LOW in signal

In order to match the operating frequency of display RAM with that of the microprocessor, some pipeline processing is internally performed which requires the insertion of a dummy read before the first actual display data read. This is shown in Figure 8-1.

Figure 8-1 : Data read back procedure - insertion of dummy read

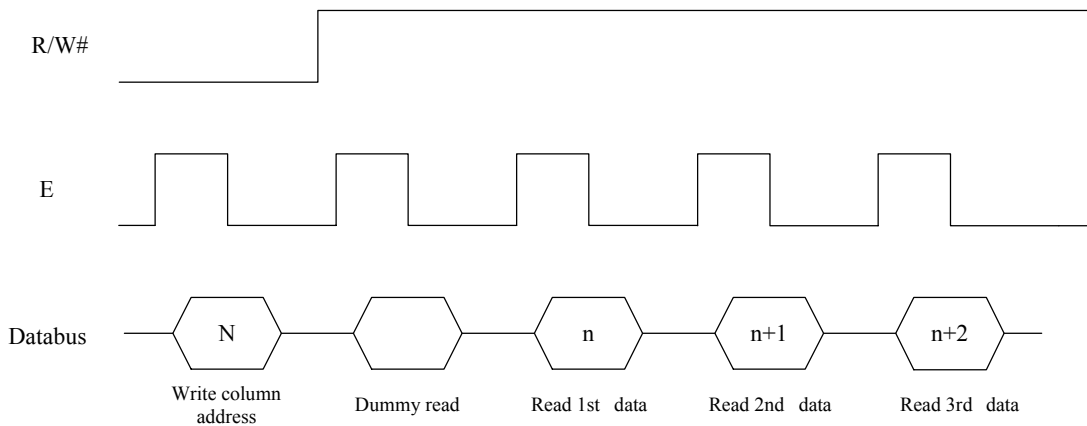

8.1.2 MCU Parallel 8080-series Interface

The parallel interface consists of 8 bi-directional data pins (D[7:0]), RD#, WR#, D/C# and CS#.

A LOW in D/C# indicates COMMAND read/write and HIGH in D/C# indicates DATA read/write.

A rising edge of RD# input serves as a data READ latch signal while CS# is kept LOW.

A rising edge of WR# input serves as a data/command WRITE latch signal while CS# is kept LOW.

Figure 8-2 : Example of Write procedure in 8080 parallel interface mode

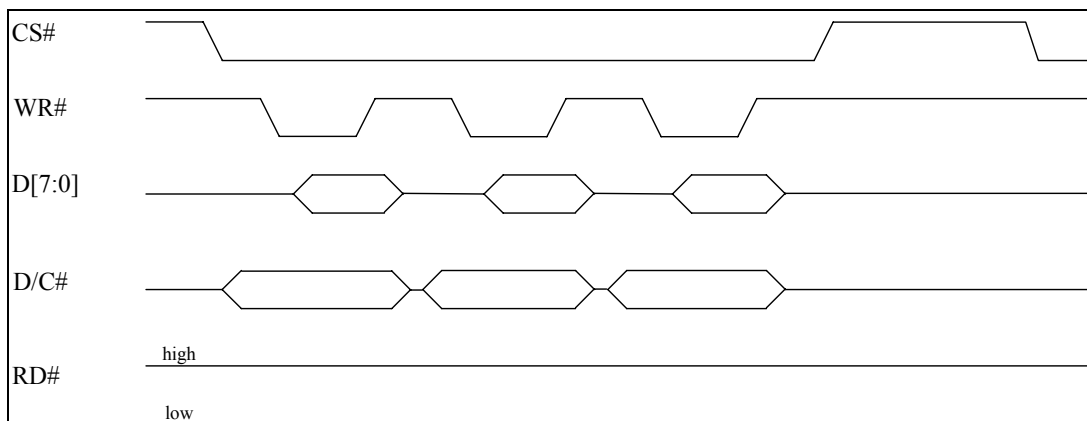

Figure 8-3 : Example of Read procedure in 8080 parallel interface mode

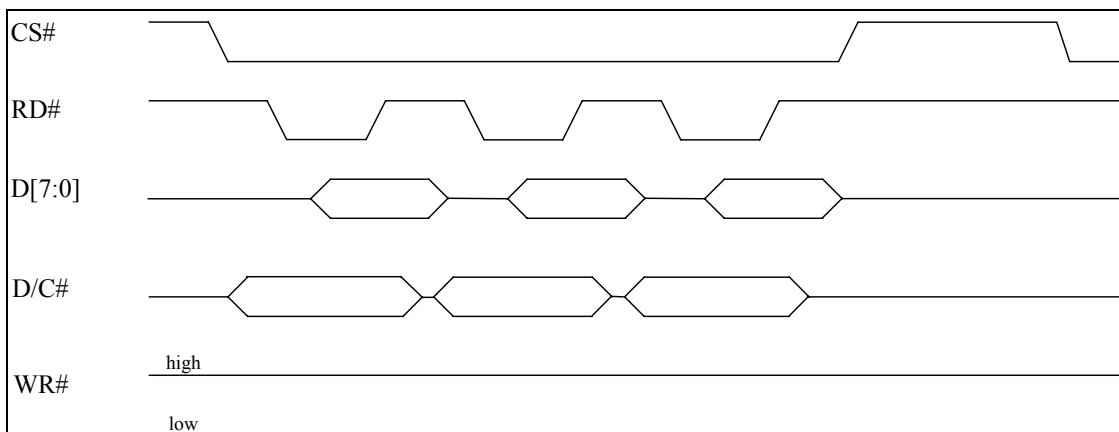

Table 8-3 : Control pins of 8080 interface (Form 1)

Function	RD#	WR#	CS#	D/C#
Write command	H	↑	L	L
Read status	↑	H	L	L
Write data	H	↑	L	H
Read data	↑	H	L	H

Note

- (1) ↑ stands for rising edge of signal
- (2) H stands for HIGH in signal
- (3) L stands for LOW in signal
- (4) Refer to Figure 13-2 for Form 1 8080-Series MPU Parallel Interface Timing Characteristics

Alternatively, RD# and WR# can be keep stable while CS# serves as the data/command latch signal.

Table 8-4 : Control pins of 8080 interface (Form 2)

Function	RD#	WR#	CS#	D/C#
Write command	H	L	↑	L
Read status	L	H	↑	L
Write data	H	L	↑	H
Read data	L	H	↑	H

Note

- (1) ↑ stands for rising edge of signal
- (2) H stands for HIGH in signal
- (3) L stands for LOW in signal
- (4) Refer to Figure 13-3 for Form 2 8080-Series MPU Parallel Interface Timing Characteristics

In order to match the operating frequency of display RAM with that of the microprocessor, some pipeline processing is internally performed which requires the insertion of a dummy read before the first actual display data read. This is shown in Figure 8-4.

Figure 8-4 : Display data read back procedure - insertion of dummy read

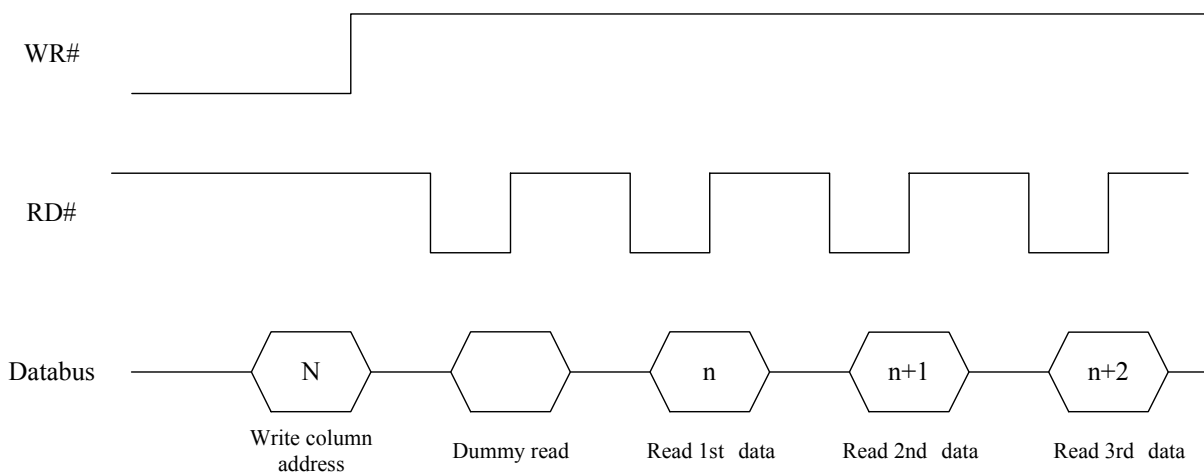

8.1.3 MCU Serial Interface

The serial interface consists of serial clock SCLK, serial data SDIN, D/C#, CS#. In SPI mode, D0 acts as SCLK, D1 acts as SDIN. For the unused data pins, D2 should be left open. The pins from D3 to D7, E and R/W# can be connected to an external ground.

Table 8-5 : Control pins of Serial interface

Function	E	R/W#	CS#	D/C#
Write command	Tie LOW	Tie LOW	L	L
Write data	Tie LOW	Tie LOW	L	H

SDIN is shifted into an 8-bit shift register on every rising edge of SCLK in the order of D7, D6, ... D0. D/C# is sampled on every eighth clock and the data byte in the shift register is written to the Graphic Display Data RAM (GDDRAM) or command register in the same clock.

Under serial mode, only write operations are allowed.

Figure 8-5 : Write procedure in SPI mode

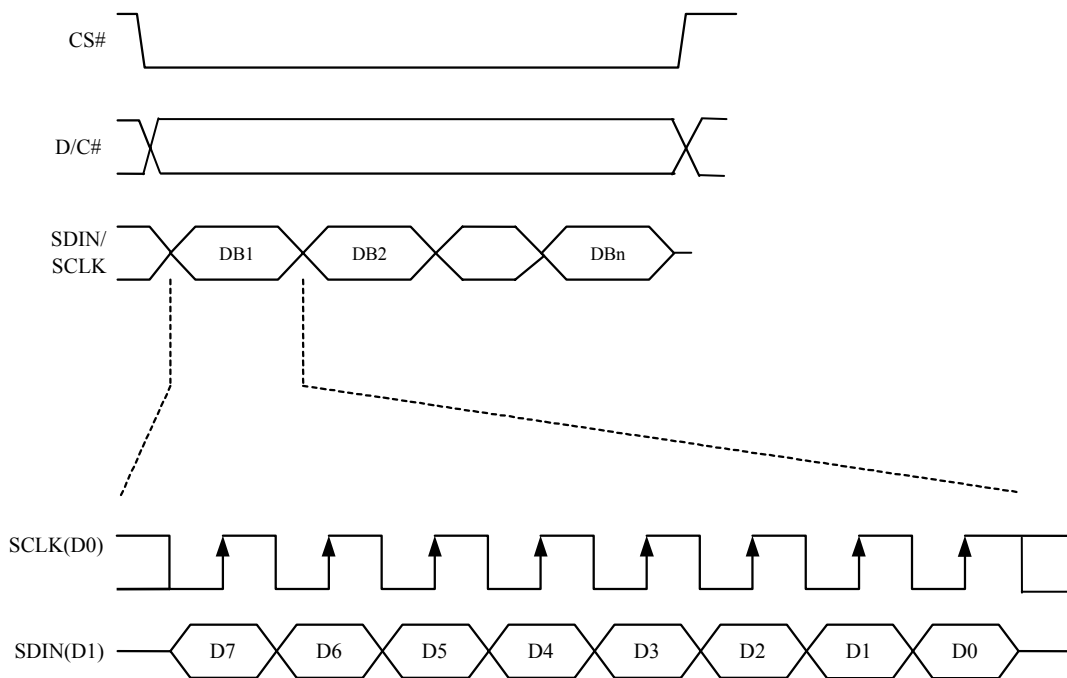

8.1.4 MCU I²C Interface

The I²C communication interface consists of slave address bit SA0, I²C-bus data signal SDA (SDA_{OUT}/D₂ for output and SDA_{IN}/D₁ for input) and I²C-bus clock signal SCL (D₀). Both the data and clock signals must be connected to pull-up resistors. RES# is used for the initialization of device.

a) Slave address bit (SA0)

SSD1305 has to recognize the slave address before transmitting or receiving any information by the I²C-bus. The device will respond to the slave address following by the slave address bit (“SA0” bit) and the read/write select bit (“R/W#” bit) with the following byte format,

b₇ b₆ b₅ b₄ b₃ b₂ b₁ b₀
 0 1 1 1 1 0 SA0 R/W#

“SA0” bit provides an extension bit for the slave address. Either “0111100” or “0111101”, can be selected as the slave address of SSD1305. D/C# pin acts as SA0 for slave address selection.

“R/W#” bit is used to determine the operation mode of the I²C-bus interface. R/W#=1, it is in read mode. R/W#=0, it is in write mode.

b) I²C-bus data signal (SDA)

SDA acts as a communication channel between the transmitter and the receiver. The data and the acknowledgement are sent through the SDA.

It should be noticed that the ITO track resistance and the pulled-up resistance at “SDA” pin becomes a voltage potential divider. As a result, the acknowledgement would not be possible to attain a valid logic 0 level in “SDA”.

“SDA_{IN}” and “SDA_{OUT}” are tied together and serve as SDA. The “SDA_{IN}” pin must be connected to act as SDA. The “SDA_{OUT}” pin may be disconnected. When “SDA_{OUT}” pin is disconnected, the acknowledgement signal will be ignored in the I²C-bus.

c) I²C-bus clock signal (SCL)

The transmission of information in the I²C-bus is following a clock signal, SCL. Each transmission of data bit is taken place during a single clock period of SCL.

8.1.4.1 I²C-bus Write data

The I²C-bus interface gives access to write data and command into the device. Please refer to Figure 8-6 for the write mode of I²C-bus in chronological order.

Figure 8-6 : I2C-bus data format

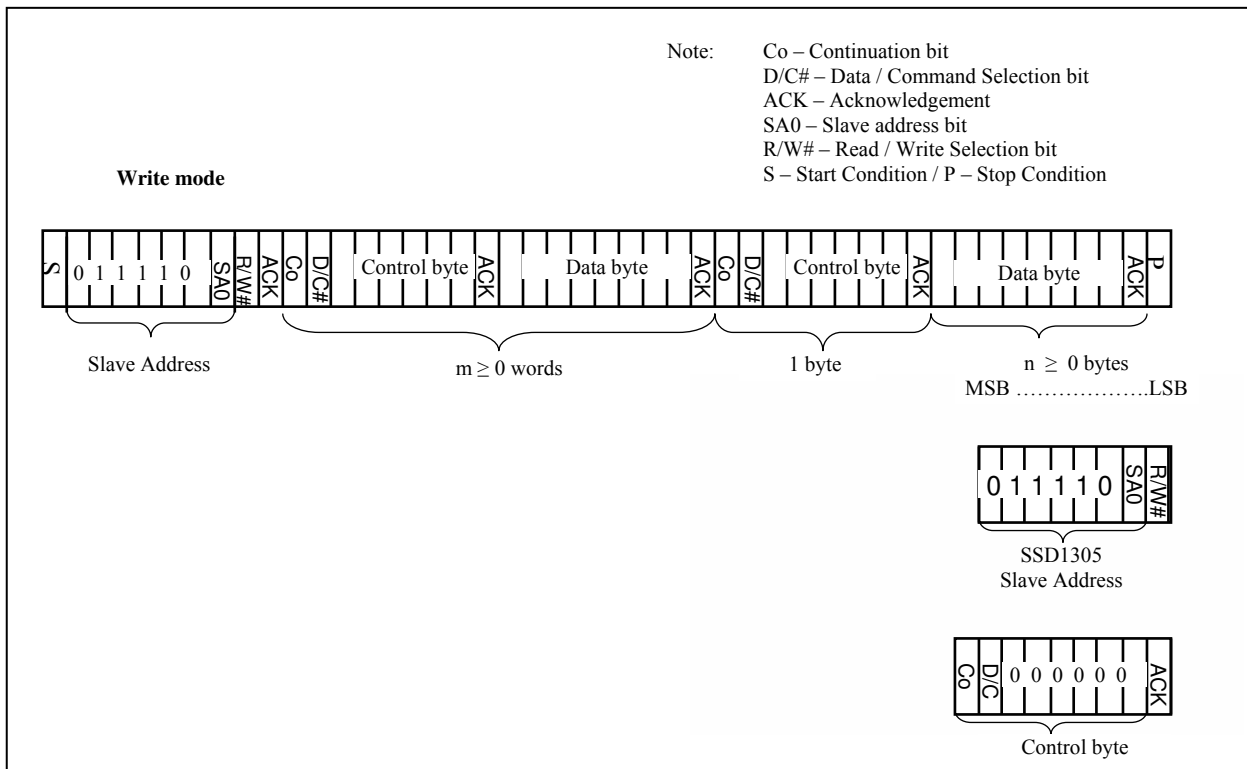

8.1.4.2 Write mode for I²C

- 1) The master device initiates the data communication by a start condition. The definition of the start condition is shown in Figure 8-7. The start condition is established by pulling the SDA from HIGH to LOW while the SCL stays HIGH.
- 2) The slave address is following the start condition for recognition use. For the SSD1305, the slave address is either “b0111100” or “b0111101” by changing the SA0 to LOW or HIGH (D/C pin acts as SA0).
- 3) The write mode is established by setting the R/W# bit to logic “0”.
- 4) An acknowledgement signal will be generated after receiving one byte of data, including the slave address and the R/W# bit. Please refer to the Figure 8-8 for the graphical representation of the acknowledge signal. The acknowledge bit is defined as the SDA line is pulled down during the HIGH period of the acknowledgement related clock pulse.
- 5) After the transmission of the slave address, either the control byte or the data byte may be sent across the SDA. A control byte mainly consists of Co and D/C# bits following by six “0” ‘s.
 - a. If the Co bit is set as logic “0”, the transmission of the following information will contain data bytes only.
 - b. The D/C# bit determines the next data byte is acted as a command or a data. If the D/C# bit is set to logic “0”, it defines the following data byte as a command. If the D/C# bit is set to logic “1”, it defines the following data byte as a data which will be stored at the GDDRAM. The GDDRAM column address pointer will be increased by one automatically after each data write.
- 6) Acknowledge bit will be generated after receiving each control byte or data byte.
- 7) The write mode will be finished when a stop condition is applied. The stop condition is also defined in Figure 8-7. The stop condition is established by pulling the “SDA in” from LOW to HIGH while the “SCL” stays HIGH.

Figure 8-7 : Definition of the Start and Stop Condition

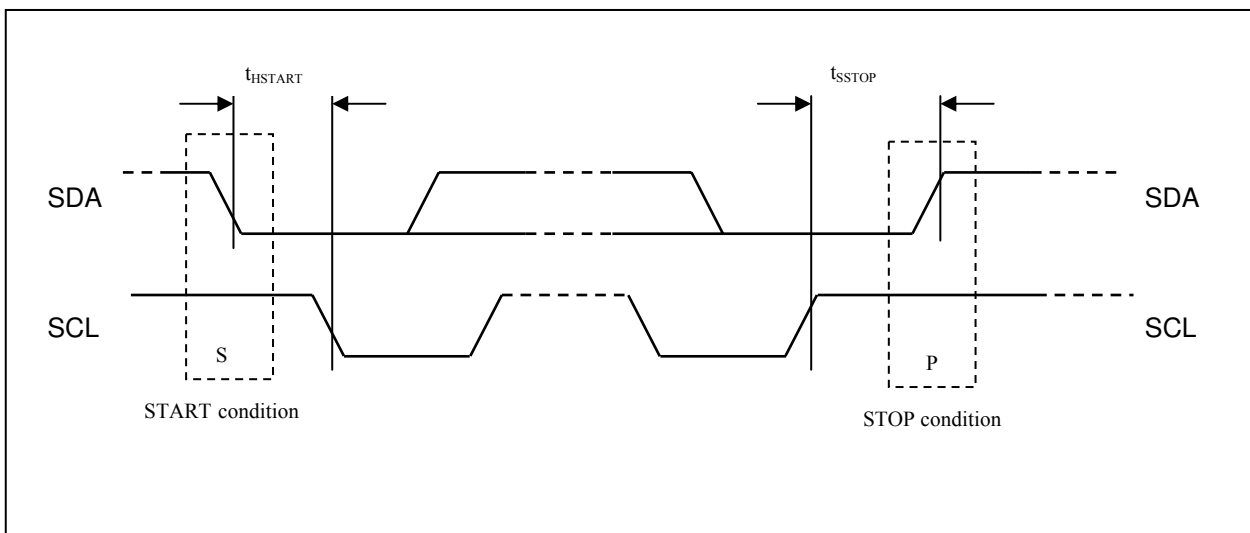
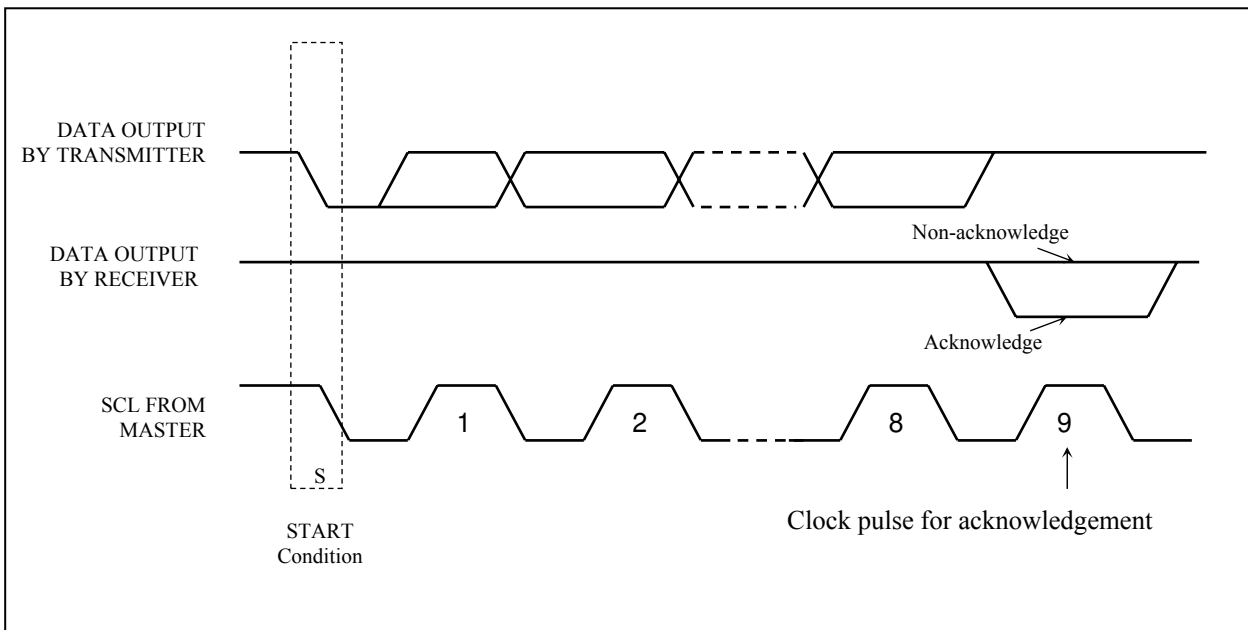

Figure 8-8 : Definition of the acknowledgement condition



Please be noted that the transmission of the data bit has some limitations.

1. The data bit, which is transmitted during each SCL pulse, must keep at a stable state within the “HIGH” period of the clock pulse. Please refer to the Figure 8-9 for graphical representations. Except in start or stop conditions, the data line can be switched only when the SCL is LOW.
2. Both the data line (SDA) and the clock line (SCL) should be pulled up by external resistors.

Figure 8-9 : Definition of the data transfer condition

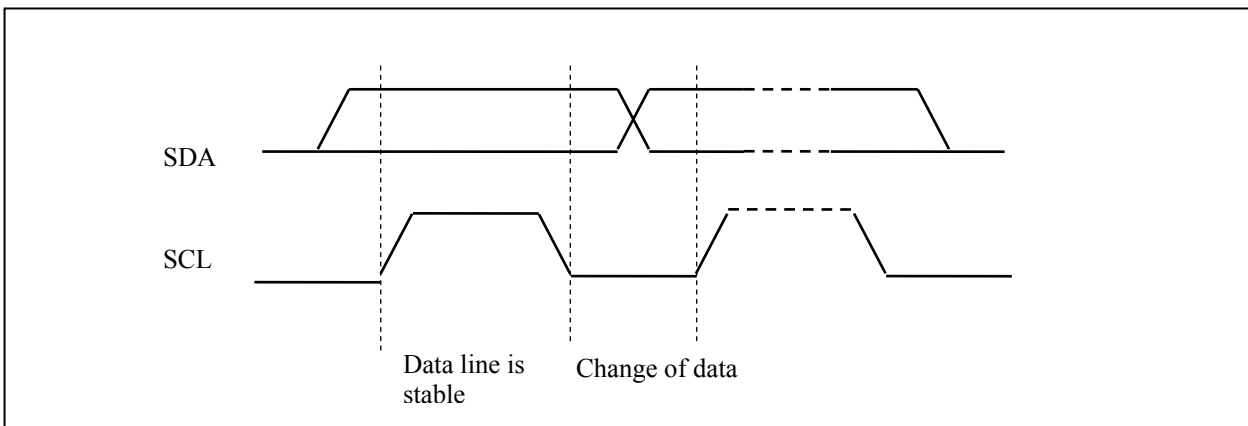

8.2 Command Decoder

This module determines whether the input data is interpreted as data or command. Data is interpreted based upon the input of the D/C# pin.

If D/C# pin is HIGH, D[7:0] is interpreted as display data written to Graphic Display Data RAM (GDDRAM). If it is LOW, the input at D[7:0] is interpreted as a command. Then data input will be decoded and written to the corresponding command register.

8.3 Oscillator Circuit and Display Time Generator

Figure 8-10 : Oscillator Circuit and Display Time Generator

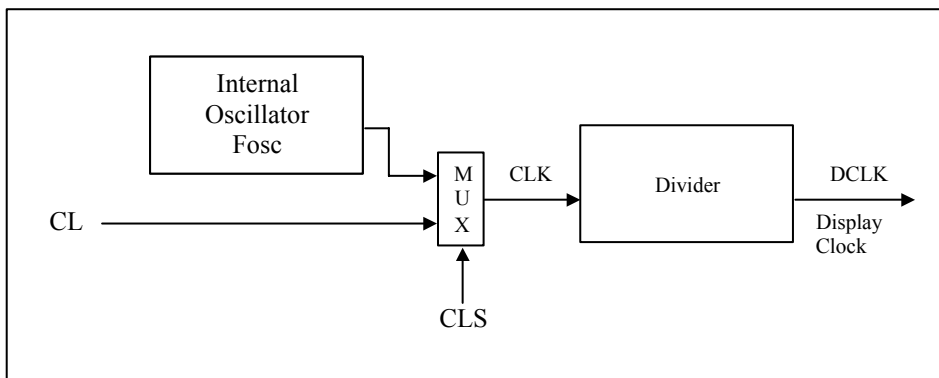

This module is an on-chip LOW power RC oscillator circuitry. The operation clock (CLK) can be generated either from internal oscillator or external source CL pin. This selection is done by CLS pin. If CLS pin is pulled HIGH, internal oscillator is chosen and CL should be left open. Pulling CLS pin LOW disables internal oscillator and external clock must be connected to CL pins for proper operation. When the internal oscillator is selected, its output frequency F_{osc} can be changed by command D5h A[7:4].

The display clock (DCLK) for the Display Timing Generator is derived from CLK. The division factor “D” can be programmed from 1 to 16 by command D5h

$$DCLK = F_{osc} / D$$

The frame frequency of display is determined by the following formula.

$$F_{FRM} = \frac{F_{osc}}{D \times K \times \text{No. of Mux}}$$

where

- D stands for clock divide ratio. It is set by command D5h A[3:0]. The divide ratio has the range from 1 to 16.
- K is the number of display clocks per row. The value is derived by
 $K = \text{Phase 1 period} + \text{Phase 2 period} + \text{BANK0 pulse width}$
 $= 2 + 2 + 50 = 54$ at power on reset
 (Please refer to Section 8.6 “Segment Drivers / Common Drivers” for the details of the “Phase”)
- Number of multiplex ratio is set by command A8h. The power on reset value is 63 (i.e. 64MUX).
- F_{osc} is the oscillator frequency. It can be changed by command D5h A[7:4]. The higher the register setting results in higher frequency.

8.4 FR synchronization

FR synchronization signal can be used to prevent tearing effect.

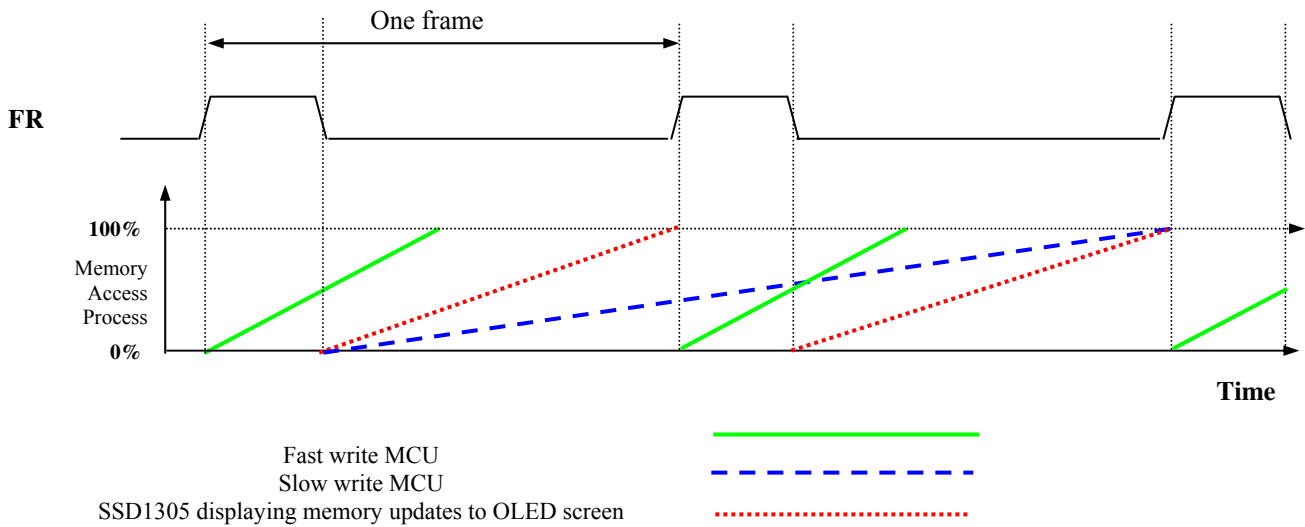

The starting time to write a new image to OLED driver is depended on the MCU writing speed. If MCU can finish writing a frame image within one frame period, it is classified as fast write MCU. For MCU needs longer writing time to complete (more than one frame but within two frames), it is a slow write one.

For fast write MCU: MCU should start to write new frame of ram data just after rising edge of FR pulse and should be finished well before the rising edge of the next FR pulse.

For slow write MCU: MCU should start to write new frame ram data after the falling edge of the 1st FR pulse and must be finished before the rising edge of the 3rd FR pulse.

8.5 Reset Circuit

When RES# input is LOW, the chip is initialized with the following status:

1. Display is OFF
2. 132 x 64 Display Mode
3. Normal segment and display data column address and row address mapping (SEG0 mapped to address 00h and COM0 mapped to address 00h)
4. Shift register data clear in serial interface
5. Display start line is set at display RAM address 0
6. Column address counter is set at 0
7. Normal scan direction of the COM outputs
8. Contrast control register is set at 80h
9. Normal display mode (Equivalent to A4h command)

8.6 Segment Drivers / Common Drivers

Segment drivers deliver 132 current sources to drive the OLED panel. The driving current can be adjusted from 0 to 320uA with 256 steps. Common drivers generate voltage-scanning pulses.

The segment driving waveform is divided into three phases:

1. In phase 1, the OLED pixel charges of previous image are discharged in order to prepare for next image content display.
2. In phase 2, the OLED pixel is driven to the targeted voltage. The pixel is driven to attain the corresponding voltage level from V_{SS} . The period of phase 2 can be programmed in length from 1 to 15 DCLKs. If the capacitance value of the pixel of OLED panel is larger, a longer period is required to charge up the capacitor to reach the desired voltage.
3. In phase 3, the OLED driver switches to use current source to drive the OLED pixels and this is the current drive stage. SSD1305 employs PWM (Pulse Width Modulation) method to control the brightness of area color A, B, C, D color individually. The longer the waveform in current drive stage is, the brighter is the pixel and vice versa.

Figure 8-11 : Segment Output Waveform in three phases

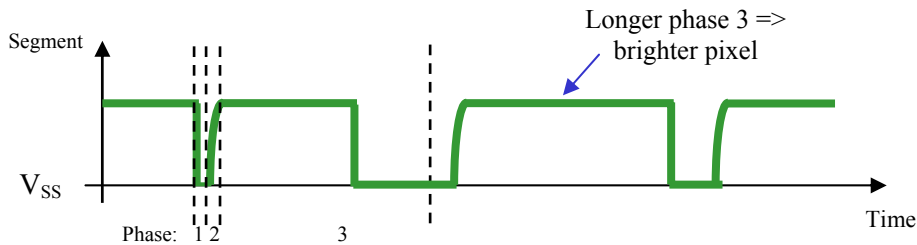

After finishing phase 3, the driver IC will go back to phase 1 to display the next row image data. This three-step cycle is run continuously to refresh image display on OLED panel.

The length of phase 3 for area colors: A,B,C and monochrome BANK0 can be configured by command 91h "Set Look Up Table". There are 64 steps available for each color but the one of color D is fixed at 64. The unit of the step is in DCLK.

For example, the look up table for area color A, B, is set to 20, 40 DCLKs respectively. Color B is set to be brighter than color A. Then the result segment output waveform of these two colors is shown below.

Figure 8-12 : Segment Output Waveform for two different colors LUT setting

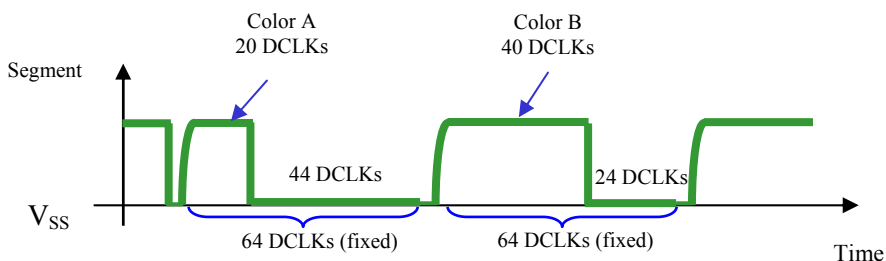

In phase 3, the segment output waveforms under the monochrome mode and area color mode are different.

In monochrome mode, if the length of current drive pulse width is set to 50, after finishing 50 DCLKs in current drive phase, the driver IC will go back to phase 1 for next row display.

Figure 8-13 : Example of Segment Output Waveform of monochrome display section under monochrome mode

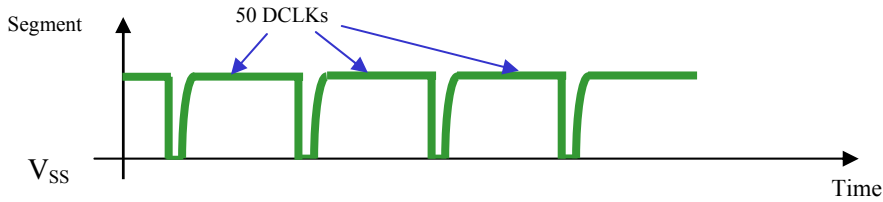

In area color mode, the phase 3 of both BANK0 and area color banks (BANK1 to BANK32) are fixed into 64 DCLKs. For instance, if the length of the pulse width is set to 50, then after the end of 50 DCLKs of current drive phase, the segment waveform will be gone to V_{SS} level and the driver is still in current drive phase. This phase will be end after 64 DCLKs from the start of the phase is passed. And then the drive goes back to phase 1 for next row display. Figure 8-14 shows the example of the segment output waveform of area color display section when the pulse width of area color is set to 50.

Figure 8-14 : Example of Segment Output Waveform of area color display section under area color mode

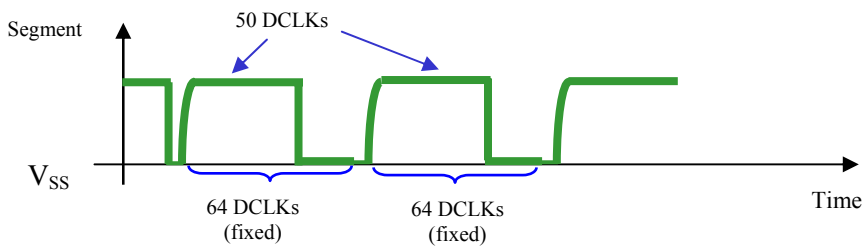

8.7 Graphic Display Data RAM (GDDRAM)

The GDDRAM is a bit mapped static RAM holding the bit pattern to be displayed. The size of the RAM is 132 x 64 bits and the RAM is divided into eight pages, from PAGE0 to PAGE7, as shown in Figure 8-15. In GDDRAM, PAGE0 and PAGE1 are belonged to area color section with resolution 132x16. PAGE2 to PAGE7 are used for monochrome 132x48 dot matrix display.

Figure 8-15 : GDDRAM pages structure of SSD1305

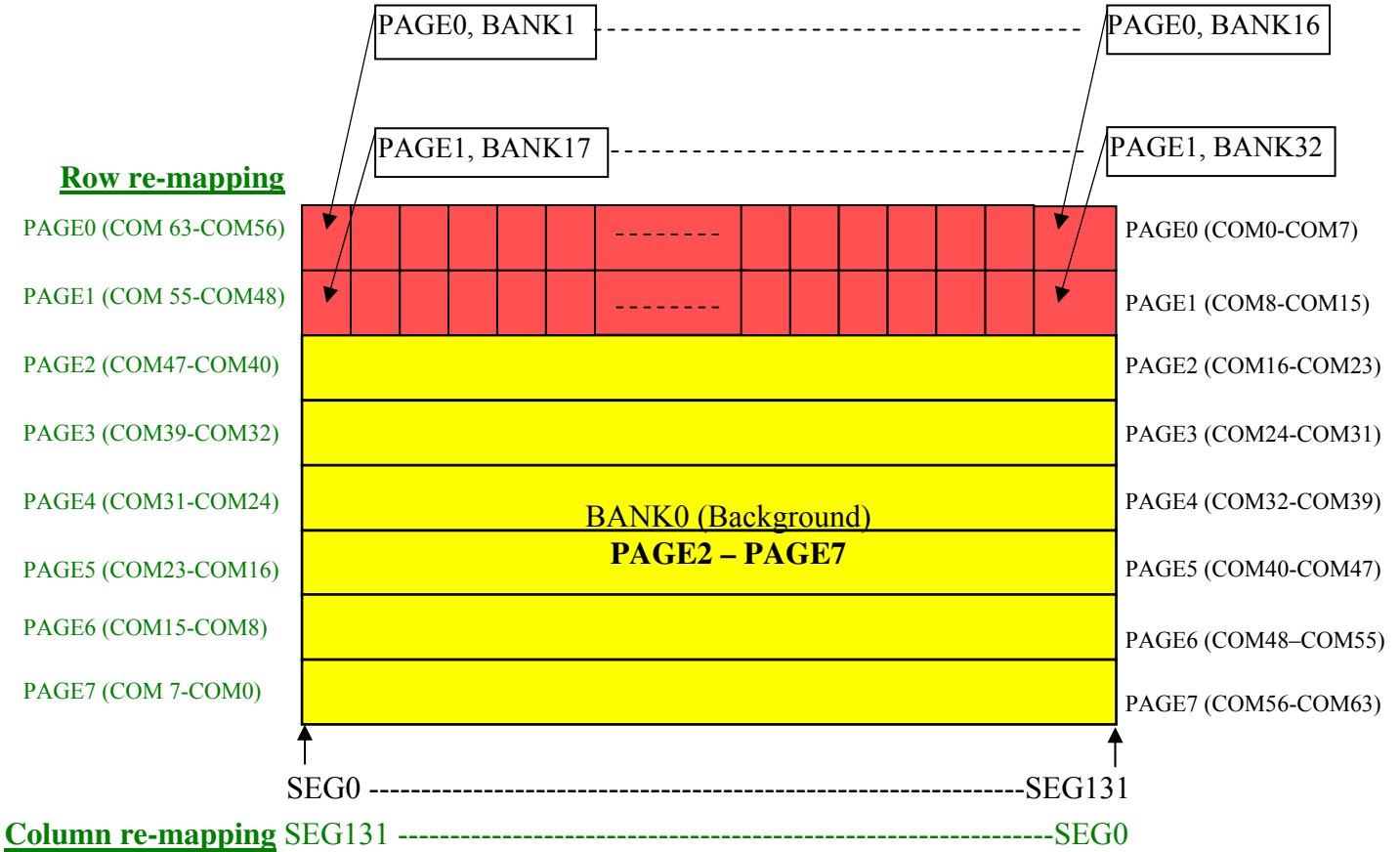

When one data byte is written into GDDRAM, all the rows image data of the same page of the current column are filled (i.e. the whole column (8 bits) pointed by the column address pointer is filled.). Data bit D0 is written into the top row, while data bit D7 is written into bottom row as shown in Figure 8-16.

Figure 8-16 : Enlargement of GDDRAM (No row re-mapping and column-remapping)

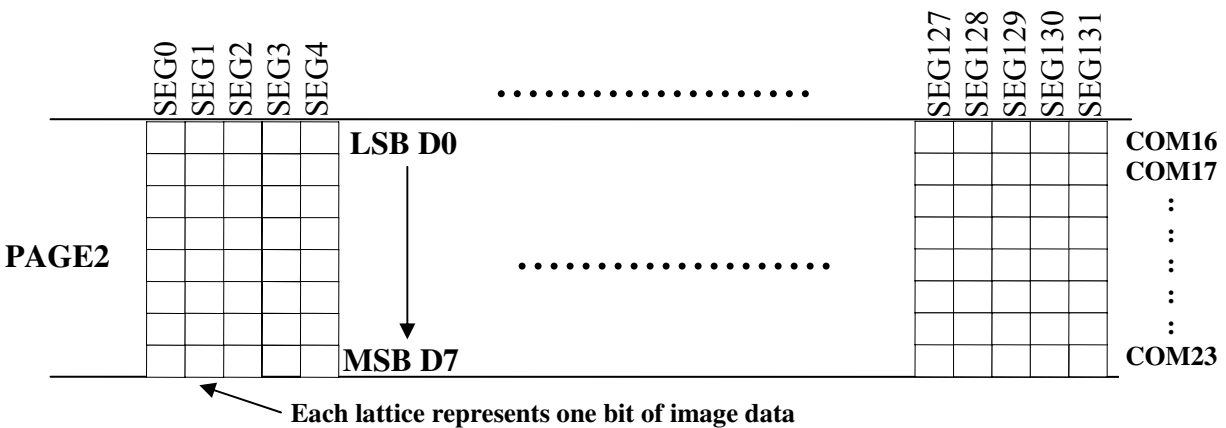

For mechanical flexibility, re-mapping on both Segment and Common outputs can be selected by software as shown in Figure 8-15.

For vertical shifting of the display, an internal register storing the display start line can be set to control the portion of the RAM data to be mapped to the display (command D3h).

8.8 Area Color Decoder

The 132x64 display matrix is divided into 8 pages. The first two pages, PAGE0 and PAGE1, are divided into 32 banks. BANK16 and BANK32 consist of a display area of 12x8 pixels. Other banks (BANK0 to BANK15 & BANK17 to BANK31) have matrices of 8x8 pixels. Each bank can be programmed to any one of the four colors (color A, B, C and D) as the example shown in Figure 8-17. Detailed operation can be referred to command 92h in Table 9-1.

Figure 8-17 : Example of area color assignment on a 132x64 OLED panel

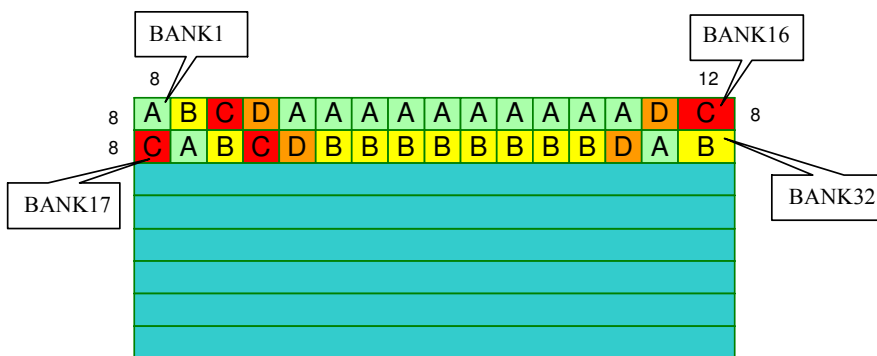

8.9 SEG/COM Driving block

This block is used to derive the incoming power sources into the different levels of internal use voltage and current.

- V_{CC} is the most positive voltage supply.
- V_{COMH} is the Common deselected level. It is internally regulated.
- V_{LSS} is the ground path of the analog and panel current.
- I_{REF} is a reference current source for segment current drivers I_{SEG} . The relationship between reference current and segment current of a color is:

$$I_{SEG} = \text{Contrast} / 256 \times I_{REF} \times \text{scale factor}$$

in which

the contrast (0~255) is set by Set Contrast command 81h; and
the scale factor is 32 by default.

The magnitude of I_{REF} is controlled by the value of resistor, which is connected between I_{REF} pin and V_{SS} as shown in Figure 8-18. It is recommended to set I_{REF} to 10uA +/- 2uA so as to achieve $I_{SEG} = 320\mu\text{A}$ at maximum contrast 255.

Figure 8-18 : I_{REF} Current Setting by Resistor Value

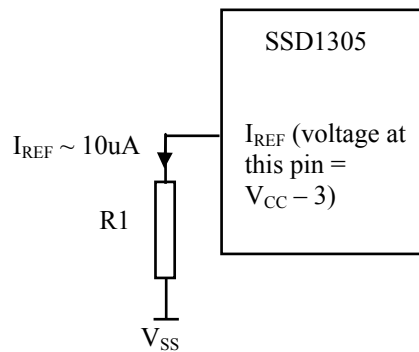

Since the voltage at I_{REF} pin is $V_{CC} - 3V$, the value of resistor $R1$ can be found as below.

$$R1 = (\text{Voltage at } I_{REF} - V_{SS}) / I_{REF} = (V_{CC} - 3) / 10\mu\text{A} \approx 910\text{k}\Omega \text{ for } V_{CC} = 12V.$$

8.10 Power ON and OFF sequence

The following figures illustrate the recommended power ON and power OFF sequence of SSD1305 (assume V_{DD} and V_{DDIO} are at the same voltage level).

Power ON sequence:

1. Power ON V_{DD} , V_{DDIO} .
2. After V_{DD} , V_{DDIO} become stable, set RES# pin LOW (logic low) for at least 3 μ s (t_1) and then HIGH (logic high).
3. After set RES# pin LOW (logic low), wait for at least 3 μ s (t_2). Then Power ON V_{CC} .⁽¹⁾
4. After V_{CC} become stable, send command AFh for display ON. SEG/COM will be ON after 100ms (t_{AF}).

Figure 8-19 : The Power ON sequence

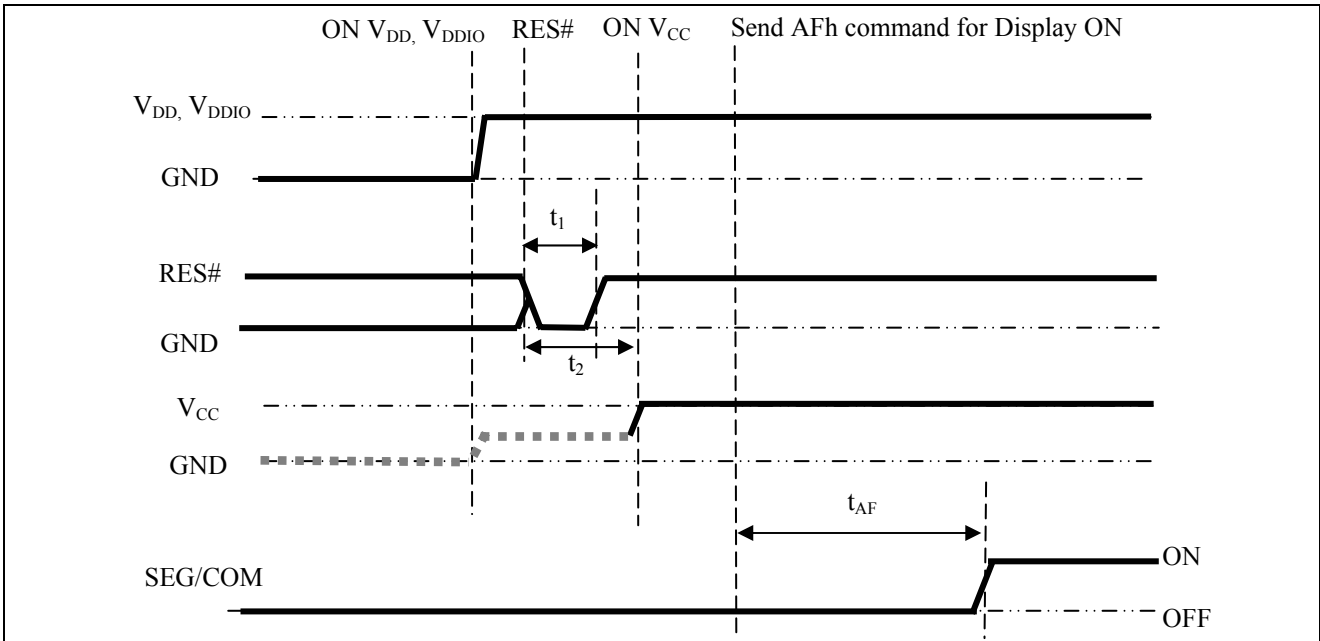

Power OFF sequence:

1. Send command AEh for display OFF.
2. Power OFF V_{CC} .^{(1), (2)}
3. Wait for t_{OFF} . Power OFF V_{DD} , V_{DDIO} . (where Minimum t_{OFF} =0ms, Typical t_{OFF} =100ms)

Figure 8-20 : The Power OFF sequence

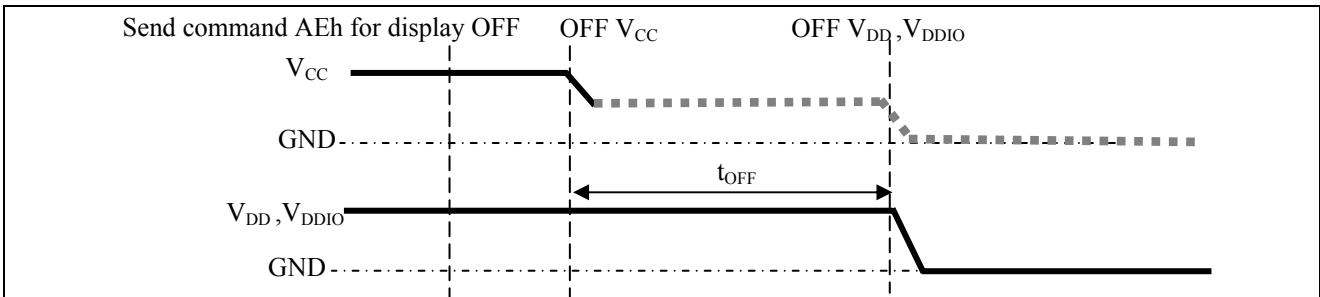

Note:

⁽¹⁾ Since an ESD protection circuit is connected between V_{DD} , V_{DDIO} and V_{CC} , V_{CC} becomes lower than V_{DD} whenever V_{DD} , V_{DDIO} is ON and V_{CC} is OFF as shown in the dotted line of V_{CC} in Figure 8-19 and Figure 8-20.

⁽²⁾ V_{CC} should be kept float (disable) when it is OFF.

8.11 DC-DC Converter

This is a switching voltage generator circuit, designed for handheld applications. In the SSD1305 an internal DC-DC voltage converter accompanying an external application circuit (See Figure 8-21 below) can generate a high voltage supply, V_{CC} , from a low voltage supply input, V_{DD} . The V_{CC} is the voltage supply to the OLED driver block. Below is an example application circuit for the input voltage of 2.8V V_{DD} to generate V_{CC} of 12V @0mA ~ 20mA application.

Figure 8-21 : DC-DC voltage converter circuit

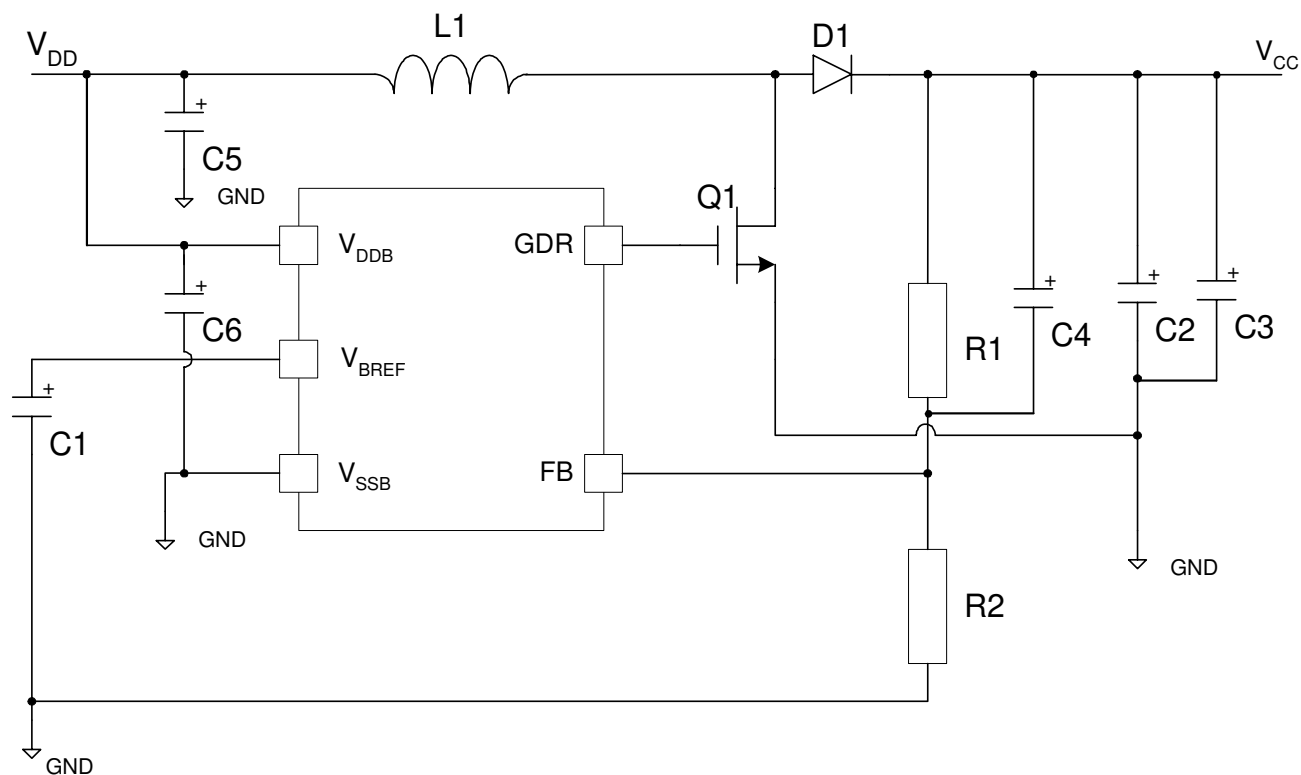

Note

- (1) L1, D1, Q1, C5 should be grouped close together on PCB layout.
- (2) R1, R2, C1 should be grouped close together on PCB layout.
- (3) The V_{CC} output voltage level can be adjusted by R1 and R2, the reference formula is:

$$V_{CC} = 0.8x (R_1 + R_2) / R_2$$

The value of $(R_1 + R_2)$ should be between 500k Ω . to 2M Ω .

Table 8-6 : Passive component selection

Components	Typical Value	Remark
L1	Inductor, 22uH	Over 0.5A current rating Low DC resistance
D1	Schottky diode	MBR0530 [On Semiconductor] 0.5A
Q1	MOSFET	NTA4153N [On Semiconductor] Low Rds (Drain- source resistance) Over 0.5A current rating
R1	Resistor, 1M Ω	1%
R2	Resistor, 75K Ω	1%
C1	Capacitor, 68nF	6V
C2	Capacitor, 10uF	16V
C3	Capacitor, 10nF	16V
C4	Capacitor, 10nF	16V
C5	Capacitor, 10uF	16V
C6	Capacitor, 10nF	16V

9 COMMAND TABLE

Table 9-1: Command Table

(D/C#=0, R/W#(WR#) = 0, E(RD#=1) unless specific setting is stated)

Fundamental Command Table											
D/C#	Hex	D7	D6	D5	D4	D3	D2	D1	D0	Command	Description
0	00~0F	0	0	0	0	X ₃	X ₂	X ₁	X ₀	Set Lower Column Start Address for Page Addressing Mode	Set the lower nibble of the column start address register for Page Addressing Mode using X[3:0] as data bits. The initial display line register is reset to 0000b after RESET.
0	10~1F	0	0	0	1	X ₃	X ₂	X ₁	X ₀	Set Higher Column Start Address for Page Addressing Mode	Set the higher nibble of the column start address register for Page Addressing Mode using X[3:0] as data bits. The initial display line register is reset to 0000b after RESET.
0 0	20 A[1:0]	0 *	0 *	1 *	0 *	0 *	0 *	0 A ₁	0 A ₀	Set Memory Addressing Mode	A[1:0] = 00b, Horizontal Addressing Mode A[1:0] = 01b, Vertical Addressing Mode A[1:0] = 10b, Page Addressing Mode (RESET) A[1:0] = 11b, Invalid
0 0 0	21 A[7:0] B[7:0]	0 A ₇ B ₇	0 A ₆ B ₆	1 A ₅ B ₅	0 A ₄ B ₄	0 A ₃ B ₃	0 A ₂ B ₂	0 A ₁ B ₁	1 A ₀ B ₀	Set Column Address	Setup column start and end address A[7:0] : Column start address, range : 0-131d, (RESET=0d) B[7:0]: Column end address, range : 0-131d, (RESET =131d)
0 0 0	22 A[2:0] B[2:0]	0 * *	0 * *	1 * *	0 * *	0 * *	0 A ₂ B ₂	1 A ₁ B ₁	0 A ₀ B ₀	Set Page Address	Setup page start and end address A[2:0] : Page start Address, range : 0-7d, (RESET = 0d) B[2:0] : Page end Address, range : 0-7d, (RESET = 7d)
0	40~7F	0	1	X ₅	X ₄	X ₃	X ₂	X ₁	X ₀	Set Display Start Line	Set display RAM display start line register from 0-63 using X ₅ X ₃ X ₂ X ₁ X ₀ . Display start line register is reset to 000000b during RESET.
0 0	81 A[7:0]	1 A ₇	0 A ₆	0 A ₅	0 A ₄	0 A ₃	0 A ₂	0 A ₁	1 A ₀	Set Contrast Control For BANK0	Double byte command to select 1 out of 256 contrast steps. Contrast increases as the value increases. (RESET = 80h)
0 0	82 A[7:0]	1 A ₇	0 A ₆	0 A ₅	0 A ₄	0 A ₃	0 A ₂	1 A ₁	0 A ₀	Set Brightness For Area Color Banks	Double byte command to select 1 out of 256 brightness steps. Brightness increases as the value increases. (RESET = 80h)
0 0 0 0 0	91 X[5:0] A[5:0] B[5:0] C[5:0]	1 * * * *	0 * * * *	0 X ₅ A ₅ B ₅ C ₅	1 X ₄ A ₄ B ₄ C ₄	0 X ₃ A ₃ B ₃ C ₃	0 X ₂ A ₂ B ₂ C ₂	0 X ₁ A ₁ B ₁ C ₁	1 X ₀ A ₀ B ₀ C ₀	Set Look Up Table (LUT)	Set current drive pulse width of BANK0, Color A, B and C. BANK0: X[5:0] = 31... 63; for pulse width set to 32 ~ 64 clocks (RESET = 110001b) Color A: A[5:0] same as above (RESET = 111111b) Color B: B[5:0] same as above (RESET = 111111b) Color C: C[5:0] same as above (RESET = 111111b) Note (¹) Color D pulse width is fixed at 64 clocks pulse.

Fundamental Command Table											
D/C#	Hex	D7	D6	D5	D4	D3	D2	D1	D0	Command	Description
0 0 0 0 0	92 A[7:0] B[7:0] C[7:0] D[7:0]	1 A ₇ B ₇ C ₇ D ₇	0 A ₆ B ₆ C ₆ D ₆	0 A ₅ B ₅ C ₅ D ₅	1 A ₄ B ₄ C ₄ D ₄	0 A ₃ B ₃ C ₃ D ₃	0 A ₂ B ₂ C ₂ D ₂	1 A ₁ B ₁ C ₁ D ₁	0 A ₀ B ₀ C ₀ D ₀	Set Bank Color of BANK1 to BANK16 (PAGE0)	Set the bank color of BANK1~BANK16 to any one of the 4 colors : A, B, C and D . A[1:0] : 00b, 01b, 10b, or 11b for Color = A, B, C or D of BANK1 A[3:2] : 00b, 01b, 10b, or 11b for Color = A, B, C or D of BANK2 : : : D[5:4]: 00b, 01b, 10b, or 11b for Color = A, B, C or D of BANK15 D[7:6]: 00b, 01b, 10b, or 11b for Color = A, B, C or D of BANK16
0 0 0 0 0	93 A[7:0] B[7:0] C[7:0] D[7:0]	1 A ₇ B ₇ C ₇ D ₇	0 A ₆ B ₆ C ₆ D ₆	0 A ₅ B ₅ C ₅ D ₅	1 A ₄ B ₄ C ₄ D ₄	0 A ₃ B ₃ C ₃ D ₃	0 A ₂ B ₂ C ₂ D ₂	1 A ₁ B ₁ C ₁ D ₁	1 A ₀ B ₀ C ₀ D ₀	Set Bank Color of BANK17~BANK32 (PAGE1)	Set the bank color of BANK17~BANK32 to any one of the 4 colors: A, B, C and D. A[1:0] : 00b, 01b, 10b, or 11b for Color = A, B, C or D of BANK17 A[3:2] : 00b, 01b, 10b, or 1b1 for Color = A, B, C or D of BANK18 : : : D[5:4]: 00b, 01b, 10b, or 11b for Color = A, B, C or D of BANK31 D[7:6]: 00b, 01b, 10b, or 11b for Color = A, B, C or D of BANK32
0	A0/A1	1	0	1	0	0	0	0	X ₀	Set Segment Re-map	X[0]=0b: column address 0 is mapped to SEG0 (RESET) X[0]=1b: column address 131 is mapped to SEG0
0	A4/A5	1	0	1	0	0	1	0	X ₀	Entire Display ON	X ₀ =0b: Resume to RAM content display (RESET) Output follows RAM content X ₀ =1b: Entire display ON Output ignores RAM content
0	A6/A7	1	0	1	0	0	1	1	X ₀	Set Normal/Inverse Display	X[0]=0b: Normal display (RESET) 0 in RAM: OFF in display panel 1 in RAM: ON in display panel X[0]=1b: inverse display 0 in RAM: ON in display panel 1 in RAM: OFF in display panel
0 0	A8 A[5:0]	1 *	0 *	1 A ₅	0 A ₄	1 A ₃	0 A ₂	0 A ₁	0 A ₀	Set Multiplex Ratio	Set MUX ratio to N+1 MUX N=A[5:0] : from 16MUX to 64MUX, RESET= 111111b (i.e. 64MUX) A[5:0] from 0 to 14 are invalid entry.
0	AA	1	0	1	0	1	0	1	0	Reserved	Reserved
0 0 0 0	AB A[3:0] B[7:0] C[7:0]	1 * B ₇ C ₇	0 * B ₆ C ₆	1 * B ₅ C ₅	0 * B ₄ C ₄	1 A ₃ B ₃ C ₃	0 A ₂ B ₂ C ₂	1 A ₁ B ₁ C ₁	1 A ₀ B ₀ C ₀	Dim mode setting	A[3:0] : Reserved (set as 0000b) B [7:0] : Set contrast for BANK0, valid range 0-255d, please refer to command 81h C [7:0] : Set brightness for color bank, valid range 0-255d, please refer to command 82h

Fundamental Command Table											
D/C#	Hex	D7	D6	D5	D4	D3	D2	D1	D0	Command	Description
0 0	AD A[7:0]	1 1	0 0	1 0	0 0	1 1	1 1	0 1	1 A ₀	Master Configuration	A[0]=0b, Select external V _{CC} supply (RESET) A[0]=1b, Select internal DC-DC voltage converter Note (1) Refer to Section 8.11 for DC-DC converter details (2) The DC-DC converter must be enabled by the following command: ADh ; Master Configuration 8Fh ; Enable internal DC-DC AFh or ACh ; Display ON
0	AC AE AF	1	0	1	0	1	1	A ₁	A ₀	Set Display ON/OFF	ACh = Display ON in dim mode AEh = Display OFF (sleep mode) (RESET) AFh = Display ON in normal mode
0	B0~B7	1	0	1	1	0	X ₂	X ₁	X ₀	Set Page Start Address for Page Addressing Mode	Set GDDRAM Page Start Address (PAGE0~PAGE7) for Page Addressing Mode using X[2:0].
0	C0/C8	1	1	0	0	X ₃	0	0	0	Set COM Output Scan Direction	X[3]=0b: normal mode (RESET) Scan from COM0 to COM[N-1] X[3]=1b: remapped mode. Scan from COM[N-1] to COM0 Where N is the Multiplex ratio.
0 0	D3 A[5:0]	1 *	1 *	0 A ₅	1 A ₄	0 A ₃	0 A ₂	1 A ₁	1 A ₀	Set Display Offset	Set vertical shift by COM from 0~63. The value is reset to 00h after RESET.
0	D5 A[7:0]	1 A ₇	1 A ₆	0 A ₅	1 A ₄	0 A ₃	1 A ₂	0 A ₁	1 A ₀	Set Display Clock Divide Ratio/Oscillator Frequency	A[3:0] : Define the divide ratio (D) of the display clocks (DCLK): Divide ratio= A[3:0] + 1, RESET is 0000b (divide ratio = 1) A[7:4] : Set the Oscillator Frequency, F _{OSC} . Oscillator Frequency increases with the value of A[7:4] and vice versa. RESET is 0111b Range:0000b~1111b Frequency increases as setting value increases. Refer to section 10.1.23 for details.
0 0	D8	1 0	1 0	0 X ₅	1 X ₄	1 0	0 X ₂	0 0	0 X ₀	Set Area Color Mode ON/OFF & Low Power Display Mode	X[5:4]= 00b (RESET) : monochrome mode X[5:4]= 11b Area Color enable X[2]=0b and X[0]=0b: Normal power mode(RESET) X[2]=1b and X[0]=1b: Set low power display mode
0 0	D9 A[7:0]	1 A ₇	1 A ₆	0 A ₅	1 A ₄	1 A ₃	0 A ₂	0 A ₁	1 A ₀	Set Pre-charge Period	A[3:0] : Phase 1 period of up to 15 DCLK clocks (RESET=2h); 0 is invalid entry A[7:4] : Phase 2 period of up to 15 DCLK clocks (RESET=2h); 0 is invalid entry

Fundamental Command Table																							
D/C#	Hex	D7	D6	D5	D4	D3	D2	D1	D0	Command	Description												
0	DA	1	1	0	1	1	0	1	0	Set COM Pins Hardware Configuration	X[4]=0b, Sequential COM pin configuration X[4]=1b(RESET), Alternative COM pin configuration X[5]=0b(RESET), Disable COM Left/Right remap X[5]=1b, Enable COM Left/Right remap Please refer to Table 10-3 for details.												
0		0	0	X ₅	X ₄	0	0	1	0														
0	DB	1	1	0	1	1	0	1	1	Set V _{COMH} Deselect Level	<table border="1"> <thead> <tr> <th>A[5:2]</th> <th>Hex code</th> <th>V_{COMH} deselect level</th> </tr> </thead> <tbody> <tr> <td>0000b</td> <td>00h</td> <td>~ 0.43 x V_{CC}</td> </tr> <tr> <td>1101b</td> <td>34h</td> <td>~ 0.77 x V_{CC} (RESET)</td> </tr> <tr> <td>1111b</td> <td>3Ch</td> <td>~ 0.83 x V_{CC}</td> </tr> </tbody> </table>	A[5:2]	Hex code	V _{COMH} deselect level	0000b	00h	~ 0.43 x V _{CC}	1101b	34h	~ 0.77 x V _{CC} (RESET)	1111b	3Ch	~ 0.83 x V _{CC}
A[5:2]	Hex code	V _{COMH} deselect level																					
0000b	00h	~ 0.43 x V _{CC}																					
1101b	34h	~ 0.77 x V _{CC} (RESET)																					
1111b	3Ch	~ 0.83 x V _{CC}																					
0	A[5:2]	0	0	A ₅	A ₄	A ₃	A ₂	0	0														
0	E0	1	1	1	0	0	0	0	0	Enter Read Modify Write	Enter the Read Modify Write mode. Details please refer to section 10.1.28.												
0	E3	1	1	1	0	0	0	1	1	NOP	Command for no operation												
0	EE	1	1	1	0	1	1	1	0	Exit Read Modify Write	Exit the Read Modify Write mode (Please refer to command E0h)												

Graphic Acceleration Command Table

D/C#	Hex	D7	D6	D5	D4	D3	D2	D1	D0	Command	Description																										
0	26/27	0	0	1	0	0	1	1	X ₀	Horizontal Scroll Setup	X[0]=0, Right Horizontal Scroll X[0]=1, Left Horizontal Scroll A[2:0] : Set number of column scroll offset 000b No horizontal scroll 001b Horizontal scroll by 1 column 010b Horizontal scroll by 2 columns 011b Horizontal scroll by 3 columns 100b Horizontal scroll by 4 columns Other values are invalid. B[2:0] : Define start page address <table border="1"> <tr> <td>000b – PAGE0</td> <td>011b – PAGE3</td> <td>110b – PAGE6</td> </tr> <tr> <td>001b – PAGE1</td> <td>100b – PAGE4</td> <td>111b – PAGE7</td> </tr> <tr> <td>010b – PAGE2</td> <td>101b – PAGE5</td> <td></td> </tr> </table> C[2:0] : Set time interval between each scroll step in terms of frame frequency <table border="1"> <tr> <td>000b – 6 frames</td> <td>100b – 3 frames</td> </tr> <tr> <td>001b – 32 frames</td> <td>101b – 4 frames</td> </tr> <tr> <td>010b – 64 frames</td> <td>110b – 2 frame</td> </tr> <tr> <td>011b – 128 frames</td> <td>111b – Invalid</td> </tr> </table> D[2:0] : Define end page address <table border="1"> <tr> <td>000b – PAGE0</td> <td>011b – PAGE3</td> <td>110b – PAGE6</td> </tr> <tr> <td>001b – PAGE1</td> <td>100b – PAGE4</td> <td>111b – PAGE7</td> </tr> <tr> <td>010b – PAGE2</td> <td>101b – PAGE5</td> <td></td> </tr> </table> The value of D[2:0] must be larger or equal to B[2:0]	000b – PAGE0	011b – PAGE3	110b – PAGE6	001b – PAGE1	100b – PAGE4	111b – PAGE7	010b – PAGE2	101b – PAGE5		000b – 6 frames	100b – 3 frames	001b – 32 frames	101b – 4 frames	010b – 64 frames	110b – 2 frame	011b – 128 frames	111b – Invalid	000b – PAGE0	011b – PAGE3	110b – PAGE6	001b – PAGE1	100b – PAGE4	111b – PAGE7	010b – PAGE2	101b – PAGE5	
000b – PAGE0	011b – PAGE3	110b – PAGE6																																			
001b – PAGE1	100b – PAGE4	111b – PAGE7																																			
010b – PAGE2	101b – PAGE5																																				
000b – 6 frames	100b – 3 frames																																				
001b – 32 frames	101b – 4 frames																																				
010b – 64 frames	110b – 2 frame																																				
011b – 128 frames	111b – Invalid																																				
000b – PAGE0	011b – PAGE3	110b – PAGE6																																			
001b – PAGE1	100b – PAGE4	111b – PAGE7																																			
010b – PAGE2	101b – PAGE5																																				
0	A[2:0]	*	*	*	*	*	A ₂	A ₁	A ₀																												
0	B[2:0]	*	*	*	*	*	B ₂	B ₁	B ₀																												
0	C[2:0]	*	*	*	*	*	C ₂	C ₁	C ₀																												
0	D[2:0]	*	*	*	*	*	D ₂	D ₁	D ₀																												
0	29/2A	0	0	1	0	1	0	X ₁	X ₀	Continuous Vertical and Horizontal Scroll Setup	X ₁ X ₀ =01b : Vertical and Right Horizontal Scroll X ₁ X ₀ =10b : Vertical and Left Horizontal Scroll A[2:0] : Set number of column scroll offset 000b No horizontal scroll 001b Horizontal scroll by 1 column 010b Horizontal scroll by 2 columns 011b Horizontal scroll by 3 columns 100b Horizontal scroll by 4 columns Other values are invalid. B[2:0] : Define start page address <table border="1"> <tr> <td>000b – PAGE0</td> <td>011b – PAGE3</td> <td>110b – PAGE6</td> </tr> <tr> <td>001b – PAGE1</td> <td>100b – PAGE4</td> <td>111b – PAGE7</td> </tr> <tr> <td>010b – PAGE2</td> <td>101b – PAGE5</td> <td></td> </tr> </table> C[2:0] : Set time interval between each scroll step in terms of frame frequency <table border="1"> <tr> <td>000b – 6 frames</td> <td>100b – 3 frames</td> </tr> <tr> <td>001b – 32 frames</td> <td>101b – 4 frames</td> </tr> <tr> <td>010b – 64 frames</td> <td>110b – 2 frame</td> </tr> <tr> <td>011b – 128 frames</td> <td>111b – Invalid</td> </tr> </table> D[2:0] : Define end page address <table border="1"> <tr> <td>000b – PAGE0</td> <td>011b – PAGE3</td> <td>110b – PAGE6</td> </tr> <tr> <td>001b – PAGE1</td> <td>100b – PAGE4</td> <td>111b – PAGE7</td> </tr> <tr> <td>010b – PAGE2</td> <td>101b – PAGE5</td> <td></td> </tr> </table> The value of D[2:0] must be larger or equal to B[2:0] E[5:0] : Vertical scrolling offset e.g. E[5:0]= 01h refer to offset =1 row E[5:0] =3Fh refer to offset =63 rows	000b – PAGE0	011b – PAGE3	110b – PAGE6	001b – PAGE1	100b – PAGE4	111b – PAGE7	010b – PAGE2	101b – PAGE5		000b – 6 frames	100b – 3 frames	001b – 32 frames	101b – 4 frames	010b – 64 frames	110b – 2 frame	011b – 128 frames	111b – Invalid	000b – PAGE0	011b – PAGE3	110b – PAGE6	001b – PAGE1	100b – PAGE4	111b – PAGE7	010b – PAGE2	101b – PAGE5	
000b – PAGE0	011b – PAGE3	110b – PAGE6																																			
001b – PAGE1	100b – PAGE4	111b – PAGE7																																			
010b – PAGE2	101b – PAGE5																																				
000b – 6 frames	100b – 3 frames																																				
001b – 32 frames	101b – 4 frames																																				
010b – 64 frames	110b – 2 frame																																				
011b – 128 frames	111b – Invalid																																				
000b – PAGE0	011b – PAGE3	110b – PAGE6																																			
001b – PAGE1	100b – PAGE4	111b – PAGE7																																			
010b – PAGE2	101b – PAGE5																																				
0	A[2:0]	*	*	*	*	*	A ₂	A ₁	A ₀																												
0	B[2:0]	*	*	*	*	*	B ₂	B ₁	B ₀																												
0	C[2:0]	*	*	*	*	*	C ₂	C ₁	C ₀																												
0	D[2:0]	*	*	*	*	*	D ₂	D ₁	D ₀																												
0	E[5:0]	*	*	E ₅	E ₄	E ₃	E ₂	E ₁	E ₀																												

Graphic Acceleration Command Table

D/C#	Hex	D7	D6	D5	D4	D3	D2	D1	D0	Command	Description
0	2E	0	0	1	0	1	1	1	0	Deactivate scroll	<p>Stop scrolling that is configured by command 26h/27h/29h/2Ah.</p> <p>Note ⁽¹⁾ After sending 2Eh command to deactivate the scrolling action, the ram data needs to be rewritten.</p>
0	2F	0	0	1	0	1	1	1	1	Activate scroll	<p>Start scrolling that is configured by the scrolling setup commands :26h/27h/29h/2Ah with the following valid sequences: Valid command sequence 1: 26h ;2Fh. Valid command sequence 2: 27h ;2Fh. Valid command sequence 3: 29h ;2Fh. Valid command sequence 4: 2Ah ;2Fh.</p> <p>For example, if “26h; 2Ah; 2Fh.” commands are issued, the setting in the last scrolling setup command, i.e. 2Ah in this case, will be executed. In other words, setting in the last scrolling setup command overwrites the setting in the previous scrolling setup commands.</p>
0 0 0	A3 A[5:0] B[6:0]	1 * *	0 * B ₆	1 A ₅ B ₅	0 A ₄ B ₄	0 A ₃ B ₃	0 A ₂ B ₂	1 A ₁ B ₁	1 A ₀ B ₀	Set Vertical Scroll Area	<p>A[5:0] : Set No. of rows in top fixed area. The No. of rows in top fixed area is referenced to the top of the GDDRAM (i.e. row 0).[RESET = 0]</p> <p>B[6:0] : Set No. of rows in scroll area. This is the number of rows to be used for vertical scrolling. The scroll area starts in the first row below the top fixed area. [RESET = 64]</p> <p>Note ⁽¹⁾ A[5:0]+B[6:0] <= MUX ratio ⁽²⁾ B[6:0] <= MUX ratio ^(3a) Vertical scrolling offset (E[5:0] in 29h/2Ah) < B[6:0] ^(3b) Set Display Start Line (X5X4X3X2X1X0 of 40h~7Fh) < B[6:0] ⁽⁴⁾ The last row of the scroll area shifts to the first row of the scroll area. ⁽⁵⁾ For 64d MUX display A[5:0] = 0, B[6:0]=64 : whole area scrolls A[5:0]= 0, B[6:0] < 64 : top area scrolls A[5:0] + B[6:0] < 64 : central area scrolls A[5:0] + B[6:0] = 64 : bottom area scrolls Please refer to Figure 10-14 for details.</p>

Note

⁽¹⁾ “*” stands for “Don’t care”.

Table 9-2 : Read Command Table

Bit Pattern	Command	Description
D ₇ D ₆ D ₅ D ₄ D ₃ D ₂ D ₁ D ₀	Status Register Read	D[7] : Reserve D[6] : “1” for display OFF / “0” for display ON D[5] : Reserve D[4] : Reserve D[3] : Reserve D[2] : Reserve D[1] : Reserve D[0] : Reserve

Note

⁽¹⁾ Patterns other than those given in the Command Table are prohibited to enter the chip as a command; as unexpected results can occur.

9.1 Data Read / Write

To read data from the GDDRAM, select HIGH for both the R/W# (WR#) pin and the D/C# pin for 6800-series parallel mode and select LOW for the E (RD#) pin and HIGH for the D/C# pin for 8080-series parallel mode. No data read is provided in serial mode operation.

In normal data read mode the GDDRAM column address pointer will be increased automatically by one after each data read.

Also, a dummy read is required before the first data read.

To write data to the GDDRAM, select LOW for the R/W# (WR#) pin and HIGH for the D/C# pin for both 6800-series parallel mode and 8080-series parallel mode. The serial interface mode is always in write mode. The GDDRAM column address pointer will be increased automatically by one after each data write.

Table 9-3 : Address increment table (Automatic)

D/C#	R/W# (WR#)	Comment	Address Increment
0	0	Write Command	No
0	1	Read Status	No
1	0	Write Data	Yes
1	1	Read Data	Yes ⁽¹⁾

Note

⁽¹⁾ If read-data command is issued in read-modify-write mode no address increase occurs.

10 COMMAND DESCRIPTIONS

10.1 Fundamental Command

10.1.1 Set Lower Column Start Address for Page Addressing Mode (00h~0Fh)

This command specifies the lower nibble of the 8-bit column start address for the display data RAM under Page Addressing Mode. The column address will be incremented by each data access. Please refer to Section Table 9-1 and Section 10.1.3 for details.

10.1.2 Set Higher Column Start Address for Page Addressing Mode (10h~1Fh)

This command specifies the higher nibble of the 8-bit column start address for the display data RAM under Page Addressing Mode. The column address will be incremented by each data access. Please refer to Section Table 9-1 and Section 10.1.3 for details.

10.1.3 Set Memory Addressing Mode (20h)

There are 3 different memory addressing mode in SSD1305: page addressing mode, horizontal addressing mode and vertical addressing mode. This command sets the way of memory addressing into one of the above three modes. In there, “COL” means the graphic display data RAM column.

Page addressing mode (A[1:0]=10xb)

In page addressing mode, after the display RAM is read/written, the column address pointer is increased automatically by 1. If the column address pointer reaches column end address, the column address pointer is reset to column start address and page address pointer is not changed. Users have to set the new page and column addresses in order to access the next page RAM content. The sequence of movement of the PAGE and column address pointer for page addressing mode is shown in Figure 10-1.

Figure 10-1 : Address Pointer Movement of Page addressing mode

	COL0	COL 1	COL 130	COL 131
PAGE0	→				
PAGE1	→				
:	:	:	:	:	:
PAGE6	→				
PAGE7	→				

In normal display data RAM read or write and page addressing mode, the following steps are required to define the starting RAM access pointer location:

- Set the page start address of the target display location by command B0h to B7h.
- Set the lower start column address of pointer by command 00h~0Fh.
- Set the upper start column address of pointer by command 10h~1Fh.

For example, if the page address is set to B2h, lower column address is 03h and upper column address is 00h, then that means the starting column is SEG3 of PAGE2. The RAM access pointer is located as shown in Figure 10-2. The input data byte will be written into RAM position of column 3.

Figure 10-2 : Example of GDDRAM access pointer setting in Page Addressing Mode (No row and column-remapping)

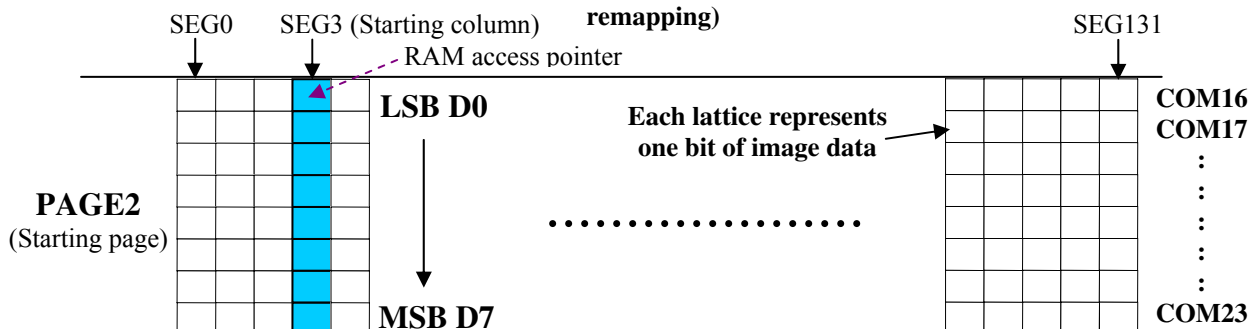

Horizontal addressing mode (A[1:0]=00b)

In horizontal addressing mode, after the display RAM is read/written, the column address pointer is increased automatically by 1. If the column address pointer reaches column end address, the column address pointer is reset to column start address and page address pointer is increased by 1. The sequence of movement of the page and column address point for horizontal addressing mode is shown in Figure 10-3. When both column and page address pointers reach the end address, the pointers are reset to column start address and page start address (Dotted line in Figure 10-3.)

Figure 10-3 : Address Pointer Movement of Horizontal addressing mode

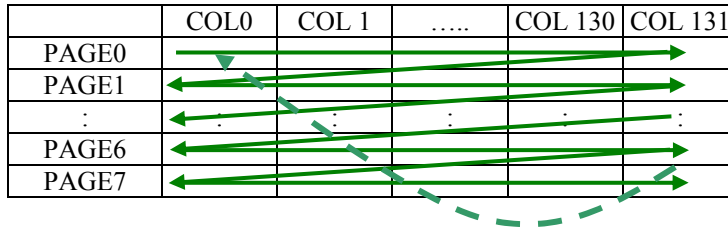

Vertical addressing mode: (A[1:0]=01b)

In vertical addressing mode, after the display RAM is read/written, the page address pointer is increased automatically by 1. If the page address pointer reaches the page end address, the page address pointer is reset to page start address and column address pointer is increased by 1. The sequence of movement of the page and column address point for vertical addressing mode is shown in Figure 10-4. When both column and page address pointers reach the end address, the pointers are reset to column start address and page start address (Dotted line in Figure 10-4.)

Figure 10-4 : Address Pointer Movement of Vertical addressing mode

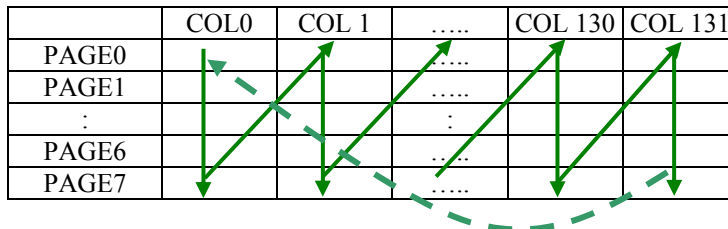

In normal display data RAM read or write and horizontal / vertical addressing mode, the following steps are required to define the RAM access pointer location:

- Set the column start and end address of the target display location by command 21h.
- Set the page start and end address of the target display location by command 22h.

Example is shown in Figure 10-5.

10.1.4 Set Column Address (21h)

This triple byte command specifies column start address and end address of the display data RAM. This command also sets the column address pointer to column start address. This pointer is used to define the current read/write column address in graphic display data RAM. If horizontal address increment mode is enabled by command 20h, after finishing read/write one column data, it is incremented automatically to the next column address. Whenever the column address pointer finishes accessing the end column address, it is reset back to start column address and the row address is incremented to the next row.

10.1.5 Set Page Address (22h)

This triple byte command specifies page start address and end address of the display data RAM. This command also sets the page address pointer to page start address. This pointer is used to define the current read/write page address in graphic display data RAM. If vertical address increment mode is enabled by command 20h, after finishing read/write one page data, it is incremented automatically to the next page address. Whenever the page address pointer finishes accessing the end page address, it is reset back to start page address.

The figure below shows the way of column and page address pointer movement through the example: column start address is set to 2 and column end address is set to 129, page start address is set to 1 and page end address is set to 6; Horizontal address increment mode is enabled by command 20h. In this case, the graphic display data RAM column accessible range is from column 2 to column 129 and from page 1 to page 6 only. In addition, the column address pointer is set to 2 and page address pointer is set to 1. After finishing read/write one pixel of data, the column address is increased automatically by 1 to access the next RAM location for next read/write operation (*solid line in Figure 10-5*). Whenever the column address pointer finishes accessing the end column 129, it is reset back to column 2 and page address is automatically increased by 1 (*solid line in Figure 10-5*). While the end page 6 and end column 129 RAM location is accessed, the page address is reset back to 1 and the column address is reset back to 2 (*dotted line in Figure 10-5*). .

Figure 10-5 : Example of Column and Row Address Pointer Movement

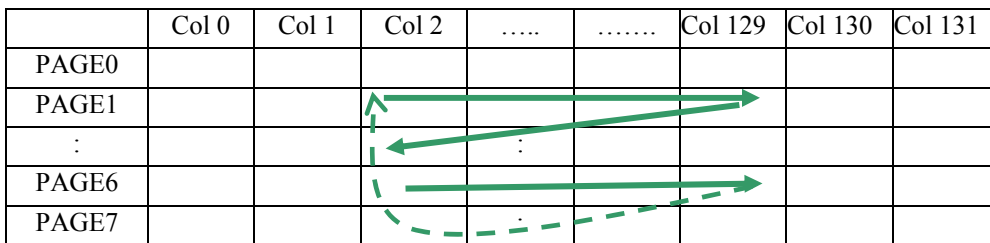

10.1.6 Set Display Start Line (40h~7Fh)

This command sets the Display Start Line register to determine starting address of display RAM, by selecting a value from 0 to 63. With value equal to 0, RAM row 0 is mapped to COM0. With value equal to 1, RAM row 1 is mapped to COM0 and so on.

Refer to Table 10-1 for more illustrations.

10.1.7 Set Contrast Control for BANK0 (81h)

This command sets the Contrast Setting of the display. The chip has 256 contrast steps from 00h to FFh. The segment output current increases as the contrast step value increases. See Figure 10-6 below.

Figure 10-6 : Segment current vs Contrast setting

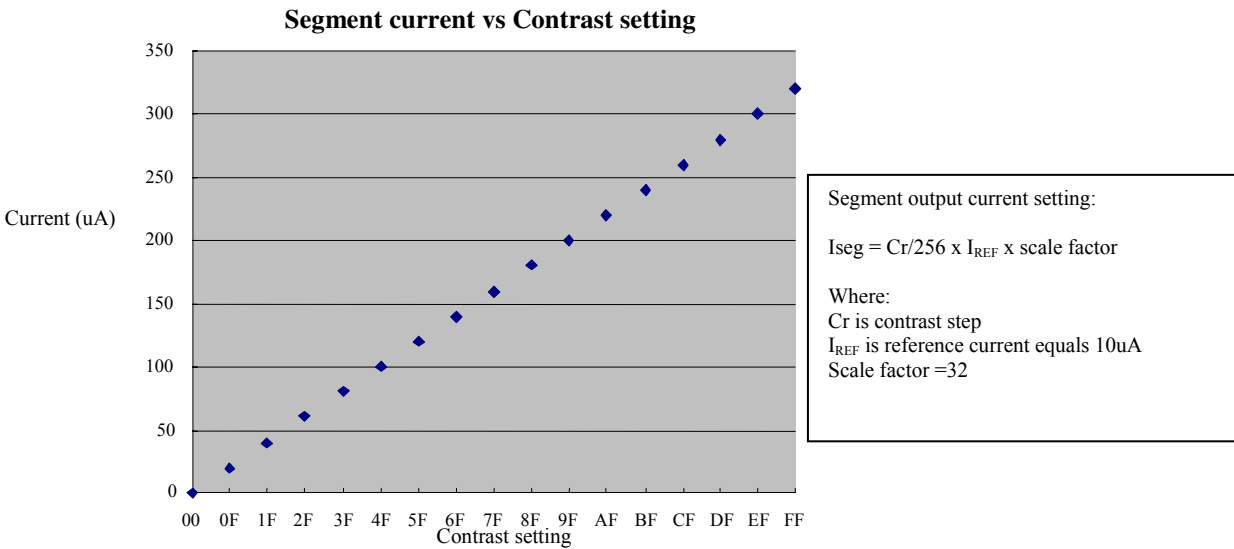

10.1.8 Set Brightness for Area Color Banks (82h)

This command sets the Brightness Setting of the display for the area color banks. The chip has 256 brightness steps from 00h to FFh. The segment output current increases as the brightness step value increases.

This setting does not affect the contrast of BANK0, which is set by command 81h.

10.1.9 Set Look Up Table (LUT) (91h)

The SSD1305 provides 4 color settings - Colors A, B, C and D for the bank color of BANK1 to BANK32 under the area color mode. The color intensity (or grey scale) is defined by the current drive pulse width. This pulse width setting must be stored in the Look Up Table (LUT). The pulse width of colors A, B, C is programmable from 32 to 64 DCLKs. The color D is fixed at 64 DCLKs pulse width. For the grey scale in BANK0, the pulse width is programmable from 32 to 64 DCLKs. Please refer to 91h command in Table 9-1 for details of the LUT setting.

After setting the pulse widths for the color of A, B, C, D and BANK0, the next step is to define the color of each display area. Each bank can be programmable to any one of the 4 colors (A, B, C and D). The user can use 92h and 93h commands for the bank color setting. It should be notice that this is only applicable in area color mode.

10.1.10 Set Bank Color of BANK1 to BANK16 (PAGE0) (92h)

This command maps the bank color (pulse width) of BANK1~BANK16 to any one of the 4 colors: A, B, C and D. For details of the setting, please refer to 92h command in Table 9-1.

10.1.11 Set Bank Color of BANK17 to BANK32 (PAGE0) (93h)

This command maps the bank color (pulse width) of BANK17~BANK32 to any one of the 4 colors: A, B, C and D. For details of the setting, please refer to 93h command in Table 9-1.

10.1.12 Set Segment Re-map (A0h/A1h)

This command changes the mapping between the display data column address and the segment driver. It allows flexibility in OLED module design. Please refer to Table 9-1.

This command only affects subsequent data input. Data already stored in GDDRAM will have no changes.

10.1.13 Entire Display ON (A4h/A5h)

A4h command enable display outputs according to the GDDRAM contents.

If A5h command is issued, then by using A4h command, the display will resume to the GDDRAM contents. In other words, A4h command resumes the display from entire display “ON” stage.

A5h command forces the entire display to be “ON”, regardless of the contents of the display data RAM.

10.1.14 Set Normal/Inverse Display (A6h/A7h)

This command sets the display to be either normal or inverse. In normal display a RAM data of 1 indicates an “ON” pixel while in inverse display a RAM data of 0 indicates an “ON” pixel.

10.1.15 Set Multiplex Ratio (A8h)

This command switches the default 63 multiplex mode to any multiplex ratio, ranging from 16 to 63. The output pads COM0~COM63 will be switched to the corresponding COM signal.

10.1.16 Reserved (AAh)

This command is reserved.

10.1.17 Dim Mode setting (ABh)

This command contains multiple bits to configure the contrast and brightness of color bank for the display in dim mode. The brightness setting of color bank can be set different to normal mode (AFh). The display can be set in dim mode through command ACh.

10.1.18 Master Configuration (ADh)

This command selects the external V_{CC} power supply or internal DC-DC voltage converter. If internal DC-DC is selected, proper external components should be connected for the generation of the V_{CC} voltage. Refer to Section 8.11 for DC-DC converter details. If external V_{CC} power supply is selected, external V_{CC} power should be connected to the V_{CC} pin.

This command will be activated after issuing Set Display ON command (ACh / AFh)

10.1.19 Set Display ON/OFF (ACh/AEh/AFh)

These single byte commands are used to turn the OLED panel display ON or OFF.

When the display is ON, the selected circuits by Set Master Configuration command will be turned ON.

When the display is OFF, those circuits will be turned OFF and the segment and common output are in high impedance state.

These commands set the display to one of the three states:

- ACh : Dim Mode Display ON
- AEh : Display OFF
- AFh : Normal Brightness Display ON

where the dim mode settings are controlled by command ABh.

Figure 10-7 :Transition between different modes

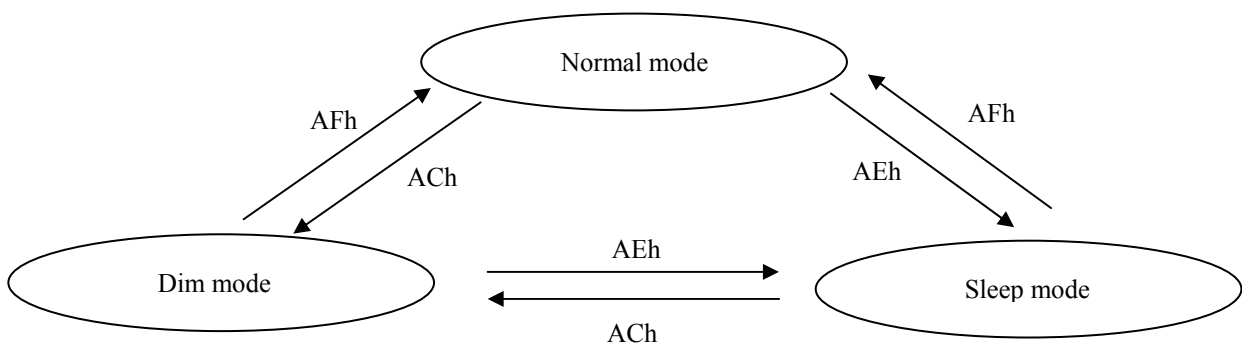

10.1.20 Set Page Start Address for Page Addressing Mode (B0h~B7h)

This command positions the page start address from 0 to 7 in GDDRAM under Page Addressing Mode. Please refer to Table 9-1 and Section 10.1.3 for details.

10.1.21 Set COM Output Scan Direction (C0h/C8h)

This command sets the scan direction of the COM output, allowing layout flexibility in the OLED module design. Additionally, the display will show once this command is issued. For example, if this command is sent during normal display then the graphic display will be vertically flipped immediately. Please refer to Table 10-3 for details.

10.1.22 Set Display Offset (D3h)

This is a double byte command. The second command specifies the mapping of the display start line to one of COM0~COM63 (assuming that COM0 is the display start line then the display start line register is equal to 0). For example, to move the COM16 towards the COM0 direction by 16 lines the 6-bit data in the second byte should be given as 010000b. To move in the opposite direction by 16 lines the 6-bit data should be given by 64 – 16, so the second byte would be 100000b.

The following two tables (Table 10-1, Table 10-2) show the example of setting the command C0h/C8h and D3h.

Table 10-1 : Example of Set Display Offset and Display Start Line with no Remap

Hardware pin name	Output												Set MUX ratio(A8h) COM Normal / Remapped (C0h / C8h) Display offset (D3h) Display start line (40h - 7Fh)
	64		64		64		56		56		56		
	Normal		Normal		Normal		Normal		Normal		Normal		
	0		8		0		0		8		8		
COM0	Row0	RAM0	Row8	RAM8	Row0	RAM8	Row0	RAM0	Row8	RAM8	Row0	RAM8	
COM1	Row1	RAM1	Row9	RAM9	Row1	RAM9	Row1	RAM1	Row9	RAM9	Row1	RAM9	
COM2	Row2	RAM2	Row10	RAM10	Row2	RAM10	Row2	RAM2	Row10	RAM10	Row2	RAM10	
COM3	Row3	RAM3	Row11	RAM11	Row3	RAM11	Row3	RAM3	Row11	RAM11	Row3	RAM11	
COM4	Row4	RAM4	Row12	RAM12	Row4	RAM12	Row4	RAM4	Row12	RAM12	Row4	RAM12	
COM5	Row5	RAM5	Row13	RAM13	Row5	RAM13	Row5	RAM5	Row13	RAM13	Row5	RAM13	
COM6	Row6	RAM6	Row14	RAM14	Row6	RAM14	Row6	RAM6	Row14	RAM14	Row6	RAM14	
COM7	Row7	RAM7	Row15	RAM15	Row7	RAM15	Row7	RAM7	Row15	RAM15	Row7	RAM15	
COM8	Row8	RAM8	Row16	RAM16	Row8	RAM16	Row8	RAM8	Row16	RAM16	Row8	RAM16	
COM9	Row9	RAM9	Row17	RAM17	Row9	RAM17	Row9	RAM9	Row17	RAM17	Row9	RAM17	
COM10	Row10	RAM10	Row18	RAM18	Row10	RAM18	Row10	RAM10	Row18	RAM18	Row10	RAM18	
COM11	Row11	RAM11	Row19	RAM19	Row11	RAM19	Row11	RAM11	Row19	RAM19	Row11	RAM19	
COM12	Row12	RAM12	Row20	RAM20	Row12	RAM20	Row12	RAM12	Row20	RAM20	Row12	RAM20	
COM13	Row13	RAM13	Row21	RAM21	Row13	RAM21	Row13	RAM13	Row21	RAM21	Row13	RAM21	
COM14	Row14	RAM14	Row22	RAM22	Row14	RAM22	Row14	RAM14	Row22	RAM22	Row14	RAM22	
COM15	Row15	RAM15	Row23	RAM23	Row15	RAM23	Row15	RAM15	Row23	RAM23	Row15	RAM23	
COM16	Row16	RAM16	Row24	RAM24	Row16	RAM24	Row16	RAM16	Row24	RAM24	Row16	RAM24	
COM17	Row17	RAM17	Row25	RAM25	Row17	RAM25	Row17	RAM17	Row25	RAM25	Row17	RAM25	
COM18	Row18	RAM18	Row26	RAM26	Row18	RAM26	Row18	RAM18	Row26	RAM26	Row18	RAM26	
COM19	Row19	RAM19	Row27	RAM27	Row19	RAM27	Row19	RAM19	Row27	RAM27	Row19	RAM27	
COM20	Row20	RAM20	Row28	RAM28	Row20	RAM28	Row20	RAM20	Row28	RAM28	Row20	RAM28	
COM21	Row21	RAM21	Row29	RAM29	Row21	RAM29	Row21	RAM21	Row29	RAM29	Row21	RAM29	
COM22	Row22	RAM22	Row30	RAM30	Row22	RAM30	Row22	RAM22	Row30	RAM30	Row22	RAM30	
COM23	Row23	RAM23	Row31	RAM31	Row23	RAM31	Row23	RAM23	Row31	RAM31	Row23	RAM31	
COM24	Row24	RAM24	Row32	RAM32	Row24	RAM32	Row24	RAM24	Row32	RAM32	Row24	RAM32	
COM25	Row25	RAM25	Row33	RAM33	Row25	RAM33	Row25	RAM25	Row33	RAM33	Row25	RAM33	
COM26	Row26	RAM26	Row34	RAM34	Row26	RAM34	Row26	RAM26	Row34	RAM34	Row26	RAM34	
COM27	Row27	RAM27	Row35	RAM35	Row27	RAM35	Row27	RAM27	Row35	RAM35	Row27	RAM35	
COM28	Row28	RAM28	Row36	RAM36	Row28	RAM36	Row28	RAM28	Row36	RAM36	Row28	RAM36	
COM29	Row29	RAM29	Row37	RAM37	Row29	RAM37	Row29	RAM29	Row37	RAM37	Row29	RAM37	
COM30	Row30	RAM30	Row38	RAM38	Row30	RAM38	Row30	RAM30	Row38	RAM38	Row30	RAM38	
COM31	Row31	RAM31	Row39	RAM39	Row31	RAM39	Row31	RAM31	Row39	RAM39	Row31	RAM39	
COM32	Row32	RAM32	Row40	RAM40	Row32	RAM40	Row32	RAM32	Row40	RAM40	Row32	RAM40	
COM33	Row33	RAM33	Row41	RAM41	Row33	RAM41	Row33	RAM33	Row41	RAM41	Row33	RAM41	
COM34	Row34	RAM34	Row42	RAM42	Row34	RAM42	Row34	RAM34	Row42	RAM42	Row34	RAM42	
COM35	Row35	RAM35	Row43	RAM43	Row35	RAM43	Row35	RAM35	Row43	RAM43	Row35	RAM43	
COM36	Row36	RAM36	Row44	RAM44	Row36	RAM44	Row36	RAM36	Row44	RAM44	Row36	RAM44	
COM37	Row37	RAM37	Row45	RAM45	Row37	RAM45	Row37	RAM37	Row45	RAM45	Row37	RAM45	
COM38	Row38	RAM38	Row46	RAM46	Row38	RAM46	Row38	RAM38	Row46	RAM46	Row38	RAM46	
COM39	Row39	RAM39	Row47	RAM47	Row39	RAM47	Row39	RAM39	Row47	RAM47	Row39	RAM47	
COM40	Row40	RAM40	Row48	RAM48	Row40	RAM48	Row40	RAM40	Row48	RAM48	Row40	RAM48	
COM41	Row41	RAM41	Row49	RAM49	Row41	RAM49	Row41	RAM41	Row49	RAM49	Row41	RAM49	
COM42	Row42	RAM42	Row50	RAM50	Row42	RAM50	Row42	RAM42	Row50	RAM50	Row42	RAM50	
COM43	Row43	RAM43	Row51	RAM51	Row43	RAM51	Row43	RAM43	Row51	RAM51	Row43	RAM51	
COM44	Row44	RAM44	Row52	RAM52	Row44	RAM52	Row44	RAM44	Row52	RAM52	Row44	RAM52	
COM45	Row45	RAM45	Row53	RAM53	Row45	RAM53	Row45	RAM45	Row53	RAM53	Row45	RAM53	
COM46	Row46	RAM46	Row54	RAM54	Row46	RAM54	Row46	RAM46	Row54	RAM54	Row46	RAM54	
COM47	Row47	RAM47	Row55	RAM55	Row47	RAM55	Row47	RAM47	Row55	RAM55	Row47	RAM55	
COM48	Row48	RAM48	Row56	RAM56	Row48	RAM56	Row48	RAM48	-	-	Row48	RAM56	
COM49	Row49	RAM49	Row57	RAM57	Row49	RAM57	Row49	RAM49	-	-	Row49	RAM57	
COM50	Row50	RAM50	Row58	RAM58	Row50	RAM58	Row50	RAM50	-	-	Row50	RAM58	
COM51	Row51	RAM51	Row59	RAM59	Row51	RAM59	Row51	RAM51	-	-	Row51	RAM59	
COM52	Row52	RAM52	Row60	RAM60	Row52	RAM60	Row52	RAM52	-	-	Row52	RAM60	
COM53	Row53	RAM53	Row61	RAM61	Row53	RAM61	Row53	RAM53	-	-	Row53	RAM61	
COM54	Row54	RAM54	Row62	RAM62	Row54	RAM62	Row54	RAM54	-	-	Row54	RAM62	
COM55	Row55	RAM55	Row63	RAM63	Row55	RAM63	Row55	RAM55	-	-	Row55	RAM63	
COM56	Row56	RAM56	Row0	RAM0	Row56	RAM0	-	-	Row0	RAM0	-	-	
COM57	Row57	RAM57	Row1	RAM1	Row57	RAM1	-	-	Row1	RAM1	-	-	
COM58	Row58	RAM58	Row2	RAM2	Row58	RAM2	-	-	Row2	RAM2	-	-	
COM59	Row59	RAM59	Row3	RAM3	Row59	RAM3	-	-	Row3	RAM3	-	-	
COM60	Row60	RAM60	Row4	RAM4	Row60	RAM4	-	-	Row4	RAM4	-	-	
COM61	Row61	RAM61	Row5	RAM5	Row61	RAM5	-	-	Row5	RAM5	-	-	
COM62	Row62	RAM62	Row6	RAM6	Row62	RAM6	-	-	Row6	RAM6	-	-	
COM63	Row63	RAM63	Row7	RAM7	Row63	RAM7	-	-	Row7	RAM7	-	-	
Display examples	(a)	(b)	(c)	(d)	(e)	(f)							



(a)



(b)



(c)



(d)



(e)



(f)



(RAM)

Table 10-2 :Example of Set Display Offset and Display Start Line with Remap

Hardw are pin name	Output														Set MUX ratio(A8h) COM Normal / Remapped (C0h / C8h) Display offset (D3h) Display start line (40h - 7Fh)
	64		64		64		48		48		48		48		
	Remap		Remap		Remap		Remap		Remap		Remap		Remap		
	0		8		0		0		8		0		8		
	0		8		8		0		0		8		16		
COM0	Row 63	RAM63	Row 7	RAM7	Row 63	RAM7	Row 47	RAM47	-	-	Row 47	RAM7	-	-	
COM1	Row 62	RAM62	Row 6	RAM6	Row 62	RAM6	Row 46	RAM46	-	-	Row 46	RAM6	-	-	
COM2	Row 61	RAM61	Row 5	RAM5	Row 61	RAM5	Row 45	RAM45	-	-	Row 45	RAM5	-	-	
COM3	Row 60	RAM60	Row 4	RAM4	Row 60	RAM4	Row 44	RAM44	-	-	Row 44	RAM4	-	-	
COM4	Row 59	RAM59	Row 3	RAM3	Row 59	RAM3	Row 43	RAM43	-	-	Row 43	RAM3	-	-	
COM5	Row 58	RAM58	Row 2	RAM2	Row 58	RAM2	Row 42	RAM42	-	-	Row 42	RAM2	-	-	
COM6	Row 57	RAM57	Row 1	RAM1	Row 57	RAM1	Row 41	RAM41	-	-	Row 41	RAM1	-	-	
COM7	Row 56	RAM56	Row 0	RAM0	Row 56	RAM0	Row 40	RAM40	-	-	Row 40	RAM0	-	-	
COM8	Row 55	RAM55	Row 63	RAM63	Row 55	RAM63	Row 39	RAM39	Row 47	RAM47	Row 39	RAM47	Row 47	RAM63	
COM9	Row 54	RAM54	Row 62	RAM62	Row 54	RAM62	Row 38	RAM38	Row 46	RAM46	Row 38	RAM46	Row 46	RAM62	
COM10	Row 53	RAM53	Row 61	RAM61	Row 53	RAM61	Row 37	RAM37	Row 45	RAM45	Row 37	RAM45	Row 45	RAM61	
COM11	Row 52	RAM52	Row 60	RAM60	Row 52	RAM60	Row 36	RAM36	Row 44	RAM44	Row 36	RAM44	Row 44	RAM60	
COM12	Row 51	RAM51	Row 59	RAM59	Row 51	RAM59	Row 35	RAM35	Row 43	RAM43	Row 35	RAM43	Row 43	RAM59	
COM13	Row 50	RAM50	Row 58	RAM58	Row 50	RAM58	Row 34	RAM34	Row 42	RAM42	Row 34	RAM42	Row 42	RAM58	
COM14	Row 49	RAM49	Row 57	RAM57	Row 49	RAM57	Row 33	RAM33	Row 41	RAM41	Row 33	RAM41	Row 41	RAM57	
COM15	Row 48	RAM48	Row 56	RAM56	Row 48	RAM56	Row 32	RAM32	Row 40	RAM40	Row 32	RAM40	Row 40	RAM56	
COM16	Row 47	RAM47	Row 55	RAM55	Row 47	RAM55	Row 31	RAM31	Row 39	RAM39	Row 31	RAM39	Row 39	RAM55	
COM17	Row 46	RAM46	Row 54	RAM54	Row 46	RAM54	Row 30	RAM30	Row 38	RAM38	Row 30	RAM38	Row 38	RAM54	
COM18	Row 45	RAM45	Row 53	RAM53	Row 45	RAM53	Row 29	RAM29	Row 37	RAM37	Row 29	RAM37	Row 37	RAM53	
COM19	Row 44	RAM44	Row 52	RAM52	Row 44	RAM52	Row 28	RAM28	Row 36	RAM36	Row 28	RAM36	Row 36	RAM52	
COM20	Row 43	RAM43	Row 51	RAM51	Row 43	RAM51	Row 27	RAM27	Row 35	RAM35	Row 27	RAM35	Row 35	RAM51	
COM21	Row 42	RAM42	Row 50	RAM50	Row 42	RAM50	Row 26	RAM26	Row 34	RAM34	Row 26	RAM34	Row 34	RAM50	
COM22	Row 41	RAM41	Row 49	RAM49	Row 41	RAM49	Row 25	RAM25	Row 33	RAM33	Row 25	RAM33	Row 33	RAM49	
COM23	Row 40	RAM40	Row 48	RAM48	Row 40	RAM48	Row 24	RAM24	Row 32	RAM32	Row 24	RAM32	Row 32	RAM48	
COM24	Row 39	RAM39	Row 47	RAM47	Row 39	RAM47	Row 23	RAM23	Row 31	RAM31	Row 23	RAM31	Row 31	RAM47	
COM25	Row 38	RAM38	Row 46	RAM46	Row 38	RAM46	Row 22	RAM22	Row 30	RAM30	Row 22	RAM30	Row 30	RAM46	
COM26	Row 37	RAM37	Row 45	RAM45	Row 37	RAM45	Row 21	RAM21	Row 29	RAM29	Row 21	RAM29	Row 29	RAM45	
COM27	Row 36	RAM36	Row 44	RAM44	Row 36	RAM44	Row 20	RAM20	Row 28	RAM28	Row 20	RAM28	Row 28	RAM44	
COM28	Row 35	RAM35	Row 43	RAM43	Row 35	RAM43	Row 19	RAM19	Row 27	RAM27	Row 19	RAM27	Row 27	RAM43	
COM29	Row 34	RAM34	Row 42	RAM42	Row 34	RAM42	Row 18	RAM18	Row 26	RAM26	Row 18	RAM26	Row 26	RAM42	
COM30	Row 33	RAM33	Row 41	RAM41	Row 33	RAM41	Row 17	RAM17	Row 25	RAM25	Row 17	RAM25	Row 25	RAM41	
COM31	Row 32	RAM32	Row 40	RAM40	Row 32	RAM40	Row 16	RAM16	Row 24	RAM24	Row 16	RAM24	Row 24	RAM40	
COM32	Row 31	RAM31	Row 39	RAM39	Row 31	RAM39	Row 15	RAM15	Row 23	RAM23	Row 15	RAM23	Row 23	RAM39	
COM33	Row 30	RAM30	Row 38	RAM38	Row 30	RAM38	Row 14	RAM14	Row 22	RAM22	Row 14	RAM22	Row 22	RAM38	
COM34	Row 29	RAM29	Row 37	RAM37	Row 29	RAM37	Row 13	RAM13	Row 21	RAM21	Row 13	RAM21	Row 21	RAM37	
COM35	Row 28	RAM28	Row 36	RAM36	Row 28	RAM36	Row 12	RAM12	Row 20	RAM20	Row 12	RAM20	Row 20	RAM36	
COM36	Row 27	RAM27	Row 35	RAM35	Row 27	RAM35	Row 11	RAM11	Row 19	RAM19	Row 11	RAM19	Row 19	RAM35	
COM37	Row 26	RAM26	Row 34	RAM34	Row 26	RAM34	Row 10	RAM10	Row 18	RAM18	Row 10	RAM18	Row 18	RAM34	
COM38	Row 25	RAM25	Row 33	RAM33	Row 25	RAM33	Row 9	RAM9	Row 17	RAM17	Row 9	RAM17	Row 17	RAM33	
COM39	Row 24	RAM24	Row 32	RAM32	Row 24	RAM32	Row 8	RAM8	Row 16	RAM16	Row 8	RAM16	Row 16	RAM32	
COM40	Row 23	RAM23	Row 31	RAM31	Row 23	RAM31	Row 7	RAM7	Row 15	RAM15	Row 7	RAM15	Row 15	RAM31	
COM41	Row 22	RAM22	Row 30	RAM30	Row 22	RAM30	Row 6	RAM6	Row 14	RAM14	Row 6	RAM14	Row 14	RAM30	
COM42	Row 21	RAM21	Row 29	RAM29	Row 21	RAM29	Row 5	RAM5	Row 13	RAM13	Row 5	RAM13	Row 13	RAM29	
COM43	Row 20	RAM20	Row 28	RAM28	Row 20	RAM28	Row 4	RAM4	Row 12	RAM12	Row 4	RAM12	Row 12	RAM28	
COM44	Row 19	RAM19	Row 27	RAM27	Row 19	RAM27	Row 3	RAM3	Row 11	RAM11	Row 3	RAM11	Row 11	RAM27	
COM45	Row 18	RAM18	Row 26	RAM26	Row 18	RAM26	Row 2	RAM2	Row 10	RAM10	Row 2	RAM10	Row 10	RAM26	
COM46	Row 17	RAM17	Row 25	RAM25	Row 17	RAM25	Row 1	RAM1	Row 9	RAM9	Row 1	RAM9	Row 9	RAM25	
COM47	Row 16	RAM16	Row 24	RAM24	Row 16	RAM24	Row 0	RAM0	Row 8	RAM8	Row 0	RAM8	Row 8	RAM24	
COM48	Row 15	RAM15	Row 23	RAM23	Row 15	RAM23	-	-	Row 7	RAM7	-	-	Row 7	RAM23	
COM49	Row 14	RAM14	Row 22	RAM22	Row 14	RAM22	-	-	Row 6	RAM6	-	-	Row 6	RAM22	
COM50	Row 13	RAM13	Row 21	RAM21	Row 13	RAM21	-	-	Row 5	RAM5	-	-	Row 5	RAM21	
COM51	Row 12	RAM12	Row 20	RAM20	Row 12	RAM20	-	-	Row 4	RAM4	-	-	Row 4	RAM20	
COM52	Row 11	RAM11	Row 19	RAM19	Row 11	RAM19	-	-	Row 3	RAM3	-	-	Row 3	RAM19	
COM53	Row 10	RAM10	Row 18	RAM18	Row 10	RAM18	-	-	Row 2	RAM2	-	-	Row 2	RAM18	
COM54	Row 9	RAM9	Row 17	RAM17	Row 9	RAM17	-	-	Row 1	RAM1	-	-	Row 1	RAM17	
COM55	Row 8	RAM8	Row 16	RAM16	Row 8	RAM16	-	-	Row 0	RAM0	-	-	Row 0	RAM16	
COM56	Row 7	RAM7	Row 15	RAM15	Row 7	RAM15	-	-	-	-	-	-	-	-	
COM57	Row 6	RAM6	Row 14	RAM14	Row 6	RAM14	-	-	-	-	-	-	-	-	
COM58	Row 5	RAM5	Row 13	RAM13	Row 5	RAM13	-	-	-	-	-	-	-	-	
COM59	Row 4	RAM4	Row 12	RAM12	Row 4	RAM12	-	-	-	-	-	-	-	-	
COM60	Row 3	RAM3	Row 11	RAM11	Row 3	RAM11	-	-	-	-	-	-	-	-	
COM61	Row 2	RAM2	Row 10	RAM10	Row 2	RAM10	-	-	-	-	-	-	-	-	
COM62	Row 1	RAM1	Row 9	RAM9	Row 1	RAM9	-	-	-	-	-	-	-	-	
COM63	Row 0	RAM0	Row 8	RAM8	Row 0	RAM8	-	-	-	-	-	-	-	-	
Display examples	(a)	(b)	(c)	(d)	(e)	(f)	(g)								



(a)



(b)



(c)



(d)



(e)



(f)



(g)



(RAM)

10.1.23 Set Display Clock Divide Ratio/ Oscillator Frequency (D5h)

This command consists of two functions:

- Display Clock Divide Ratio (D)(A[3:0])
Set the divide ratio to generate DCLK (Display Clock) from CLK. The divide ratio is from 1 to 16, with reset value = 1. Please refer to section 8.3 for the details relationship of DCLK and CLK.
- Oscillator Frequency (A[7:4])
Program the oscillator frequency Fosc that is the source of CLK if CLS pin is pulled high. The 4-bit value results in 16 different frequency settings available as shown below. The default setting is 0111b.

Figure 10-8 : Typical Oscillator frequency adjustment by D5 command (V_{DD} =2.8V)

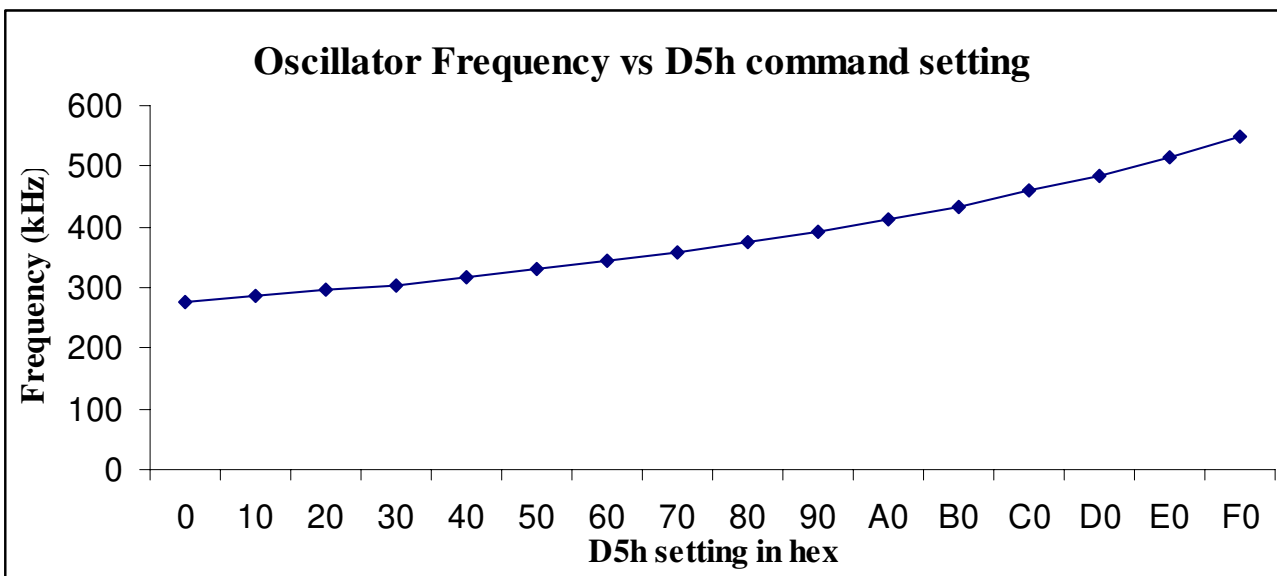

Note

⁽¹⁾ There is 10% tolerance in the above frequency values

10.1.24 Set Area Color Mode ON/OFF & Low Power Display Mode (D8h)

This command is used to enable area color mode. RESET is monochrome mode. The low power display mode can reduce power consumption during IC operation.

10.1.25 Set Pre-charge Period (D9h)

This command is used to set the duration of the pre-charge period. The interval is counted in number of DCLK, where RESET equals 2 DCLKs.

10.1.26 Set COM Pins Hardware Configuration (DAh)

This command sets the COM signals pin configuration to match the OLED panel hardware layout. The table below shows the COM pin configuration under different conditions (for MUX ratio =64):

Table 10-3 : COM Pins Hardware Configuration

Conditions	COM pins Configurations
<p>1 Sequential COM pin configuration (DAh X[4] =0) COM output Scan direction: from COM0 to COM63 (C0h) Disable COM Left/Right remap (DAh X[5] =0)</p>	
<p>2 Sequential COM pin configuration (DAh X[4] =0) COM output Scan direction: from COM0 to COM63 (C0h) Enable COM Left/Right remap (DAh X[5] =1)</p>	
<p>3 Sequential COM pin configuration (DAh X[4] =0) COM output Scan direction: from COM63 to COM0 (C8h) Disable COM Left/Right remap (DAh X[5] =0)</p>	

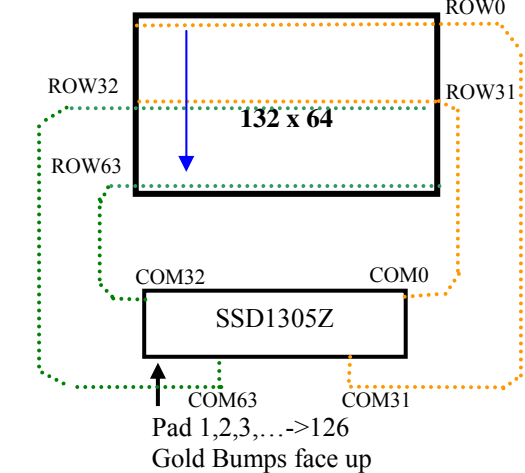
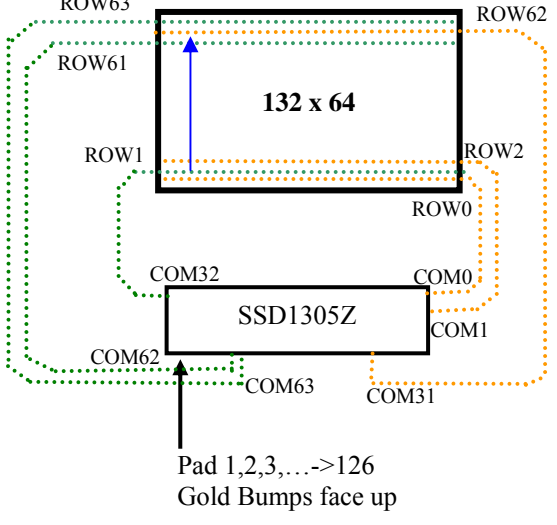
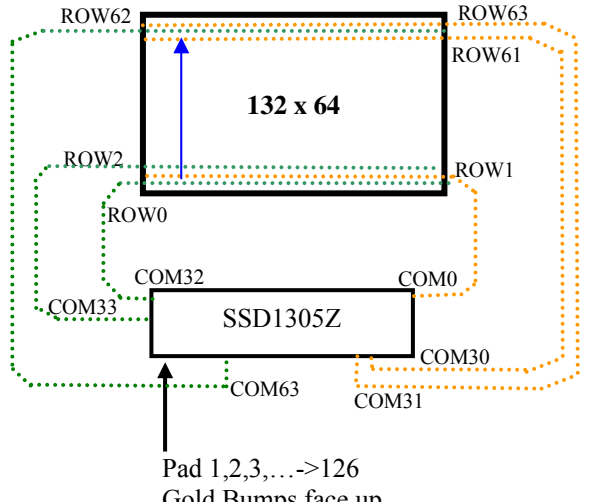
Conditions	COM pins Configurations
<p>4 Sequential COM pin configuration (DAh X[4] =0) COM output Scan direction: from COM63 to COM0 (C8h) Enable COM Left/Right remap (DAh X[5] =1)</p>	
<p>5 Alternative COM pin configuration (DAh X[4] =1) COM output Scan direction: from COM0 to COM63 (C0h) Disable COM Left/Right remap (DAh X[5] =0)</p>	
<p>6 Alternative COM pin configuration (DAh X[4] =1) COM output Scan direction: from COM0 to COM63 (C0h) Enable COM Left/Right remap (DAh X[5] =1)</p>	

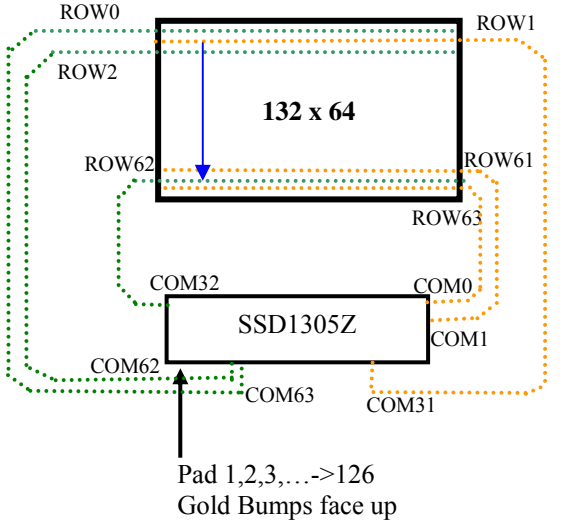
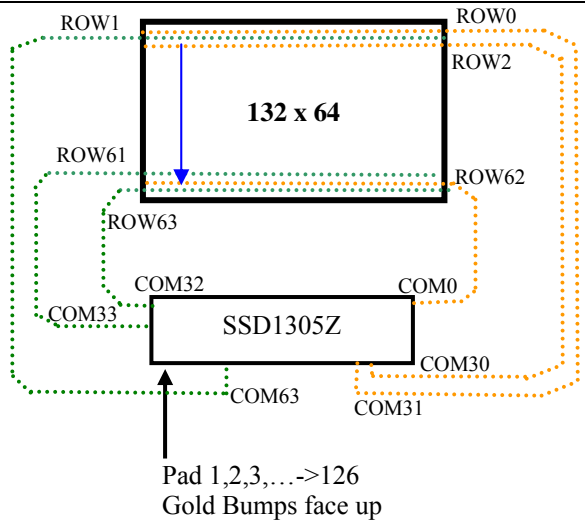
Conditions	COM pins Configurations
7 Alternative COM pin configuration (DAh X[4] =1) COM output Scan direction: from COM63 to COM0(C8h) Disable COM Left/Right remap (DAh X[5] =0)	
8 Alternative COM pin configuration (DAh X[4] =1) COM output Scan direction: from COM63 to COM0(C8h) Enable COM Left/Right remap (DAh X[5] =1)	

10.1.27 Set V_{COMH} Deselect Level (DBh)

This command adjusts the V_{COMH} regulator output.

10.1.28 Enter Read Modify Write (E0h)

This single byte command is used to enter the Read Modify Write mode.

During the Read Modify Write mode:

The RAM address pointer will not be incremented when there is data read.

The RAM address pointer will be increased by one automatically after each data write.

After exit the Read Modify Write Mode by command EEh, the RAM address pointer returns back to the original location before enter the Read Modify Write mode.

For instance, when reading the data from the RAM and re-writing a new data to the same location, there is no need to re-enter the column and page addresses again under this mode.

Table 10-4 : Example of Read Modify Write Mode

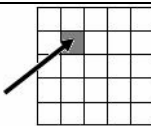
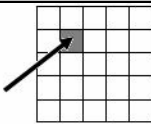
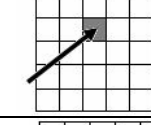
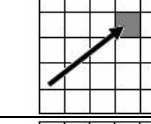
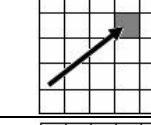
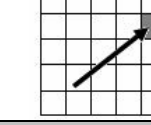
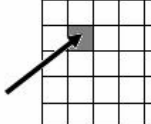
Condition	RAM & address pointer (under Horizontal addressing mode)
Originally, Address Pointer point to address A	
Enter Read Modify Write Mode by command E0h	
Data read : address pointer does not change	
Data Write: address pointer increases by one automatically after each data write	
Data Write: address pointer increases by one automatically after each data write	
Data read : address pointer does not change	
Data Write: address pointer increases by one automatically after each data write	
Exit Read Modify Write Mode by command EEh	
Address Pointer point to address A after exit Read Modify Write Mode	

10.1.29 NOP (E3h)

No Operation Command

10.1.30 Exit Read Modify Write (EEh)

This single byte command is used to exit the Read Modify Write mode (Please refer to Section 10.1.28. for details of the Read Modify Write Mode).

10.1.31 Status register Read

This command is issued by setting D/C# ON LOW during a data read (See Figure 13-1 to Figure 13-3 for parallel interface waveform). It allows the MCU to monitor the internal status of the chip. No status read is provided for serial mode.

10.2 Graphic Acceleration Command

10.2.1 Horizontal Scroll Setup (26h/27h)

This command consists of 5 consecutive bytes to set up the horizontal scroll parameters and determines the scrolling start page, end page and scrolling speed.

Before issuing this command the horizontal scroll must be deactivated (2Eh). Otherwise, RAM content may be corrupted.

The SSD1305 horizontal scroll is designed for 132 columns scrolling. The following three figures (Figure 10-9, Figure 10-10, Figure 10-11) show the examples of using the horizontal scroll:

Figure 10-9 : Horizontal scroll example: Scroll RIGHT by 4 columns

Original Setting	SEG0	SEG1	SEG2	SEG3	SEG4	SEG5	SEG126	SEG127	SEG128	SEG129	SEG130	SEG131
After one scroll step	SEG128	SEG129	SEG130	SEG131	SEG0	SEG1	SEG122	SEG123	SEG124	SEG125	SEG126	SEG127

Figure 10-10 : Horizontal scroll example: Scroll LEFT by 2 columns

Original Setting	SEG0	SEG1	SEG2	SEG3	SEG4	SEG5	SEG126	SEG127	SEG128	SEG129	SEG130	SEG131
After one scroll step	SEG2	SEG3	SEG4	SEG5	SEG6	SEG7	SEG128	SEG129	SEG130	SEG131	SEG0	SEG1

Figure 10-11 : Horizontal scrolling setup example

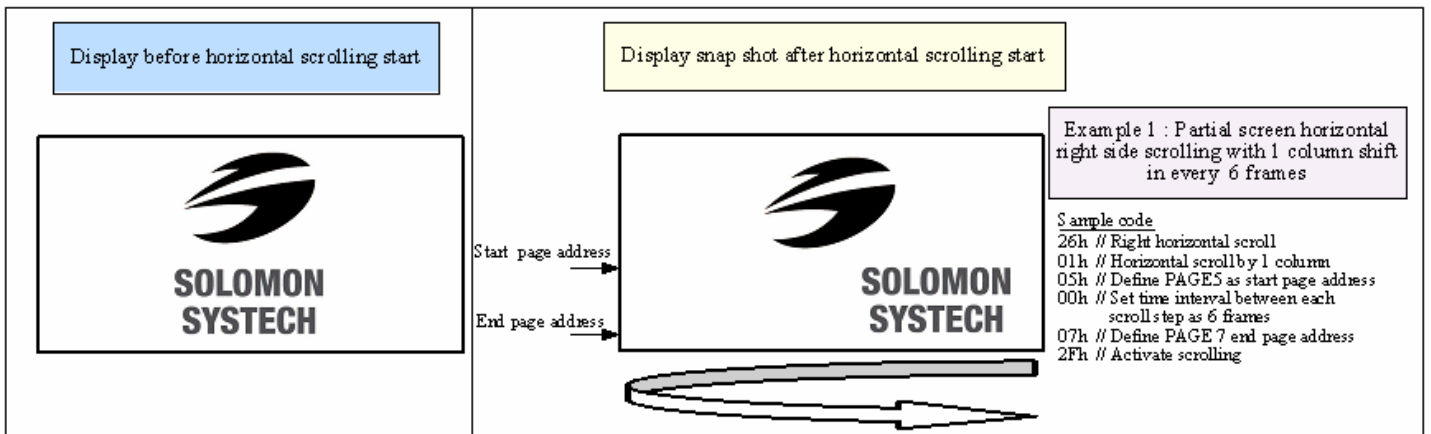

10.2.2 Continuous Vertical and Horizontal Scroll Setup (29h/2Ah)

This command consists of 6 consecutive bytes to set up the continuous vertical and horizontal scroll parameters and determines the scrolling start page, end page, scrolling speed and vertical scrolling offset.

The bytes A[2:0], B[2:0], C[2:0] and D[2:0] of command 29h/2Ah are for the setting of the continuous horizontal scrolling. The byte E[5:0] is for the setting of the continuous vertical scrolling offset. All these bytes together are for the setting of continuous diagonal (horizontal + vertical) scrolling. If the vertical scrolling offset byte E[5:0] is set to zero, then only horizontal scrolling is performed (like command 26/27h). Alternatively, if the byte A[2:0] is set to zero and E[5:0] is not set to zero, then only vertical scrolling is performed.

Before issuing this command the scroll must be deactivated (2Eh). Otherwise, RAM content may be corrupted. The following two figures (Figure 10-12 , Figure 10-13) show the examples of using the continuous vertical and horizontal scroll:

Figure 10-12 : Continuous Vertical and Horizontal scrolling setup examples

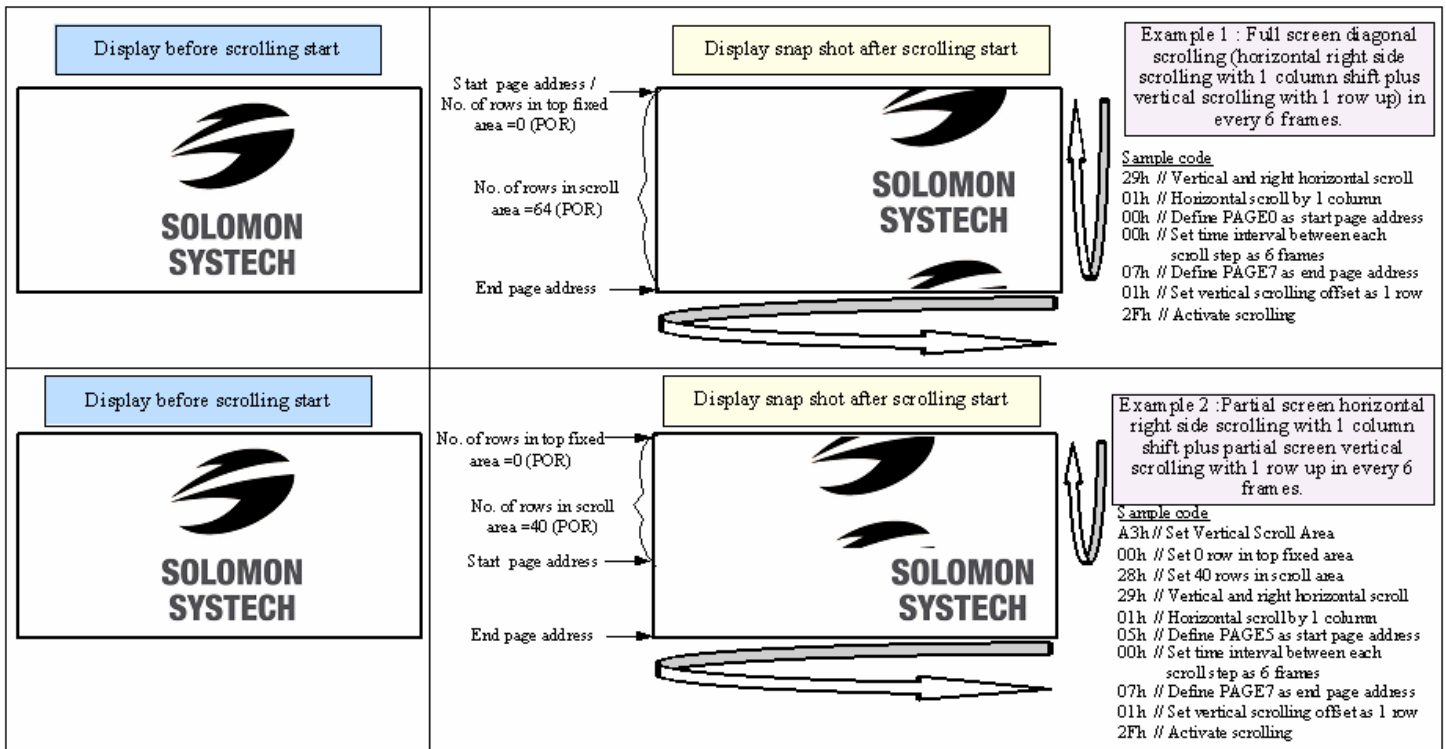
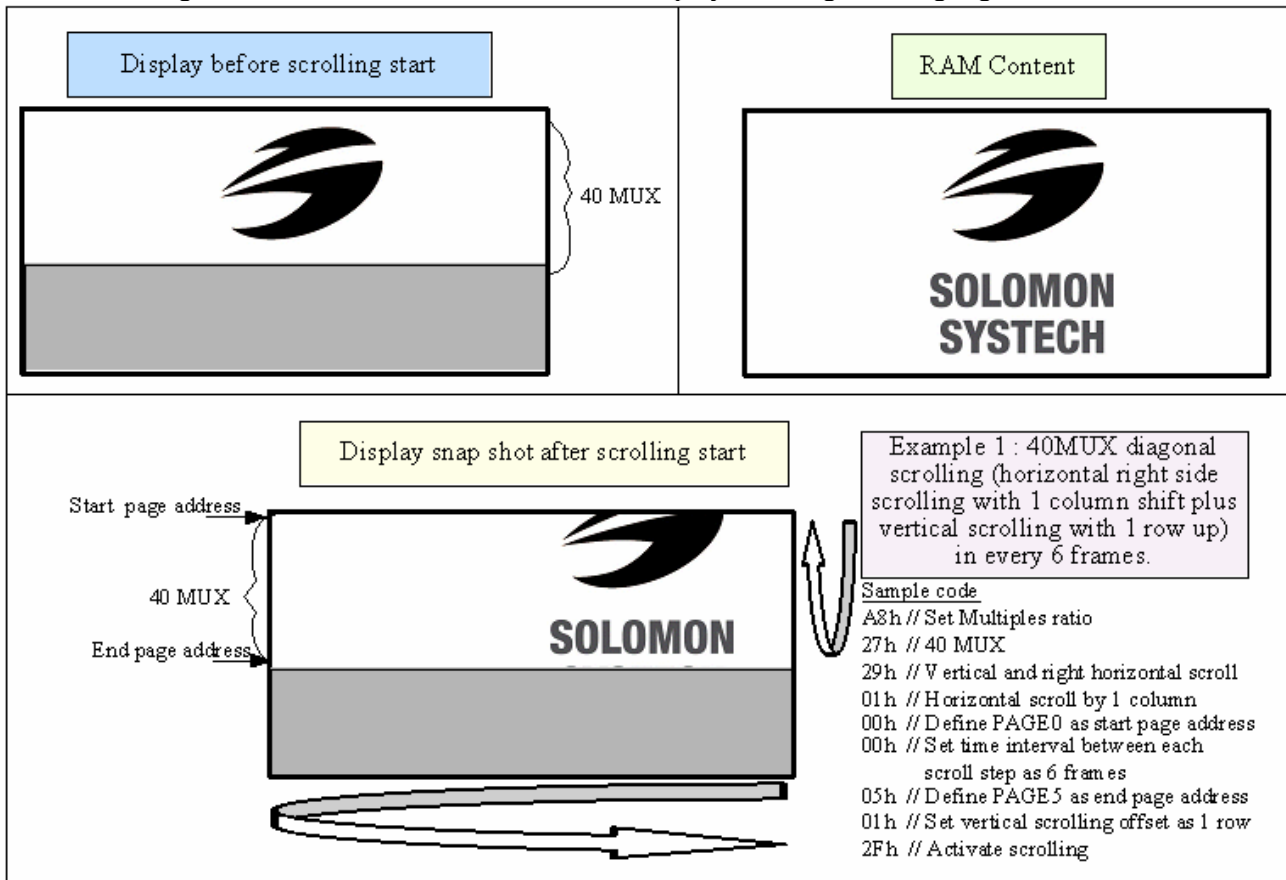

Figure 10-13 : Continuous Vertical and Horizontal scrolling example: With setting in MUX ratio

As shown in Figure 10-13, the whole RAM content is displayed during scrolling regardless of the MUX ratio.



10.2.3 Deactivate Scroll (2Eh)

This command stops the motion of scrolling. After sending 2Eh command to deactivate the scrolling action, the ram data needs to be rewritten.

10.2.4 Activate Scroll (2Fh)

This command starts the motion of scrolling and should only be issued after the scroll setup parameters have been defined by the scrolling setup commands :26h/27h/29h/2Ah . The setting in the last scrolling setup command overwrites the setting in the previous scrolling setup commands.









The following actions are prohibited after the scrolling is activated

1. RAM access (Data write or read)
2. Changing the horizontal scroll setup parameters

10.2.5 Set Vertical Scroll Area(A3h)

This command consists of 3 consecutive bytes to set up the vertical scroll area. For the continuous vertical scroll function (command 29/2Ah), the number of rows that in vertical scrolling can be set smaller or equal to the MUX ratio. Figure 10-14 shows some vertical scrolling example with different settings in vertical scroll area.

Figure 10-14 : Vertical scroll area setup examples

Display before vertical scrolling start	Display snap shot after vertical scrolling start	
	<p>No. of rows in top fixed area =0 (POR)</p> <p>No. of rows in scroll area=64 (POR)</p> 	<p>Example 1 : Full screen vertical scrolling with 1 row up in every 6 frames</p> <p>Sample code 29h // Vertical and right horizontal scroll 00h // No horizontal scroll 00h // Dummy byte for start page address 00h // Set time interval between each scroll step as 6 frames 00h // Dummy byte for end page address 01h // Set vertical scrolling offset as 1 row 2Fh // Activate scrolling</p>
	<p>No. of rows in top fixed area=0</p> <p>No. of rows in scroll area=40</p> 	<p>Example 2 : Partial screen (top area) vertical scrolling with 1 row up in every 32 frames</p> <p>Sample code A3h // Set Vertical Scroll Area 00h // Set 0 row in top fixed area 28h // Set 40 rows in scroll area 29h // Vertical and right horizontal scroll 00h // No horizontal scroll 00h // Dummy byte for start page address 01h // Set time interval between each scroll step as 32 frames 00h // Dummy byte for end page address 01h // Set vertical scrolling offset as 1 row 2Fh // Activate scrolling</p>
	<p>No. of rows in top fixed area=40</p> <p>No. of rows in scroll area=24</p> 	<p>Example 3 : Partial screen (bottom area) vertical scrolling with 1 row up in every 6 frames</p> <p>Sample code A3h // Set Vertical Scroll Area 28h // Set 40 rows in top fixed area 18h // Set 24 rows in scroll area 29h // Vertical and right horizontal scroll 00h // No horizontal scroll 00h // Dummy byte for start page address 00h // Set time interval between each scroll step as 6 frames 00h // Dummy byte for end page address 01h // Set vertical scrolling offset as 1 row 2Fh // Activate scrolling</p>
	<p>No. of rows in top fixed area=32</p> <p>No. of rows in scroll area=24</p> 	<p>Example 4 : Partial screen (central area) vertical scrolling with 1 row up in every 3 frames</p> <p>Sample code A3h // Set Vertical Scroll Area 20h // Set 32 rows in top fixed area 18h // Set 24 rows in scroll area 29h // Vertical and right horizontal scroll 00h // No horizontal scroll 00h // Dummy byte for start page address 04h // Set time interval between each scroll step as 3 frames 00h // Dummy byte for end page address 01h // Set vertical scrolling offset as 1 row 2Fh // Activate scrolling</p>

11 MAXIMUM RATINGS

Table 11-1 : Maximum Ratings (Voltage Referenced to V_{SS})

Symbol	Parameter	Value	Unit
V_{DD}	Supply Voltage	-0.3 to +4	V
V_{DDIO}		-0.3 to $V_{DD}+0.5$	V
V_{CC}		0 to 16	V
V_{SEG}	SEG output voltage	0 to V_{CC}	V
V_{COM}	COM output voltage	0 to $0.9 \cdot V_{CC}$	V
V_{in}	Input voltage	$V_{SS}-0.3$ to $V_{DD}+0.3$	V
T_A	Operating Temperature	-40 to +85	°C
T_{stg}	Storage Temperature Range	-65 to +150	°C

Maximum ratings are those values beyond which damages to the device may occur. Functional operation should be restricted to the limits in the Electrical Characteristics tables or Pin Description section

This device may be light sensitive. Caution should be taken to avoid exposure of this device to any light source during normal operation. This device is not radiation protected.

12 DC CHARACTERISTICS

Condition (Unless otherwise specified):

Voltage referenced to V_{SS}

$V_{DD} = 2.4$ to $3.5V$

$T_A = 25^\circ C$

Table 12-1 : DC Characteristics

Symbol	Parameter	Test Condition	Min	Typ	Max	Unit
V_{CC}	Operating Voltage	-	7	-	15	V
V_{DD}	Logic Supply Voltage	-	2.4	-	3.5	V
V_{DD}	Logic Supply Voltage (internal DC-DC enable)	-	2.4	-	3.5	V
V_{DDIO}	Logic Supply Voltage for MCU interface	-	1.6	-	V_{DD}	V
V_{OH}	High Logic Output Level	$I_{OUT} = 100\mu A, 3.3MHz$	$0.9 \times V_{DDIO}$	-	-	V
V_{OL}	Low Logic Output Level	$I_{OUT} = 100\mu A, 3.3MHz$	-	-	$0.1 \times V_{DDIO}$	V
V_{IH}	High Logic Input Level	-	$0.8 \times V_{DDIO}$	-	-	V
V_{IL}	Low Logic Input Level	-	-	-	$0.2 \times V_{DDIO}$	V
$I_{CC, SLEEP}$	I_{CC} Sleep mode Current	$V_{DDIO} = 1.6V \sim 3.3V, V_{DD} = 2.4V \sim 3.5V, V_{CC} = 7V \sim 15V$ Display OFF, No panel attached	-	-	10	μA
$I_{DD, SLEEP}$	I_{DD} Sleep mode Current	$V_{DDIO} = 1.6V \sim 3.3V, V_{DD} = 2.4V \sim 3.5V, V_{CC} = 7V \sim 15V$ Display OFF, No panel attached	-	-	10	μA
$I_{DDIO, SLEEP}$	I_{DDIO} Sleep mode Current	$V_{DDIO} = 1.6V \sim 3.3V, V_{DD} = 2.4V \sim 3.5V, V_{CC} = 7V \sim 15V$ Display OFF, No panel attached	-	-	10	μA
I_{CC}	V_{CC} Supply Current $V_{DD} = 2.7V, V_{CC} = 12V,$ $I_{REF} = 10\mu A$ No loading, Display ON, All ON, DC-DC converter OFF	Contrast = FFh	-	550	1000	μA
I_{DD}	V_{DD} Supply Current $V_{DD} = 2.7V, V_{CC} = 12V,$ $I_{REF} = 10\mu A$ No loading, Display ON, All ON, DC-DC converter OFF		-	100	300	μA
I_{SEG}	Segment Output Current $V_{DD} = 2.7V, V_{CC} = 12V,$ $I_{REF} = 10\mu A, Display ON.$	Contrast=FFh	294	320	346	μA
		Contrast=AFh	-	220	-	
		Contrast=7Fh	-	159	-	
		Contrast=3Fh	-	79	-	
		Contrast=0Fh	-	19	-	
Dev	Segment output current uniformity	$Dev = (I_{SEG} - I_{MID}) / I_{MID}$ $I_{MID} = (I_{MAX} + I_{MIN}) / 2$ $I_{SEG}[0:131] = \text{Segment current at contrast} = FFh$	-3	-	+3	%
Adj. Dev	Adjacent pin output current uniformity (contrast = FF)	$Adj Dev = (I[n] - I[n+1]) / (I[n] + I[n+1])$	-2	-	+2	%
V_{CC}	DC-DC converter output voltage	$V_{DD} = 2.8V$ $L = 22\mu H$ $I_{CC} = 20mA(\text{loading})$	7	-	15	V
Pwr	DC-DC converter output power	$V_{DD} \text{ input} = 2.8V,$ $L = 22\mu H;$ $V_{CC} = 15V$	-	-	300	mW

13 AC CHARACTERISTICS

Conditions:

Voltage referenced to V_{SS}

V_{DD} =2.4 to 3.5V

T_A = 25°C

Table 13-1 : AC Characteristics

Symbol	Parameter	Test Condition	Min	Typ	Max	Unit
FOSC ⁽¹⁾	Oscillation Frequency of Display Timing Generator	$V_{DD} = 2.8V$	324	360	396	kHz
FFRM	Frame Frequency for 64 MUX Mode	132x64 Graphic Display Mode, Display ON, Internal Oscillator Enabled	-	$F_{OSC} \times 1/(DxKx64)$ ⁽²⁾	-	Hz
RES#	Reset low pulse width		3	-	-	us

Note

⁽¹⁾ Fosc stands for the frequency value of the internal oscillator and the value is measured when command D5h A[7:4] is in default value.

⁽²⁾ D: divide ratio (default value = 1)

K: number of display clocks (default value = 54)

Please refer to Table 9-1 (Set Display Clock Divide Ratio/Oscillator Frequency, D5h) for detailed description

Table 13-2 : 6800-Series MCU Parallel Interface Timing Characteristics

($V_{DD} - V_{SS} = 2.4V$ to $3.5V$, $V_{DDIO} = V_{DD}$, $T_A = 25^{\circ}C$)

Symbol	Parameter	Min	Typ	Max	Unit
t_{cycle}	Clock Cycle Time	300	-	-	ns
t_{AS}	Address Setup Time	0	-	-	ns
t_{AH}	Address Hold Time	0	-	-	ns
t_{DSW}	Write Data Setup Time	40	-	-	ns
t_{DHW}	Write Data Hold Time	7	-	-	ns
t_{DHR}	Read Data Hold Time	20	-	-	ns
t_{OH}	Output Disable Time	-	-	70	ns
t_{ACC}	Access Time	-	-	140	ns
PW_{CSL}	Chip Select Low Pulse Width (read) Chip Select Low Pulse Width (write)	120 60	-	-	ns
PW_{CSH}	Chip Select High Pulse Width (read) Chip Select High Pulse Width (write)	60 60	-	-	ns
t_R	Rise Time	-	-	40	ns
t_F	Fall Time	-	-	40	ns

Figure 13-1 : 6800-series MCU parallel interface characteristics

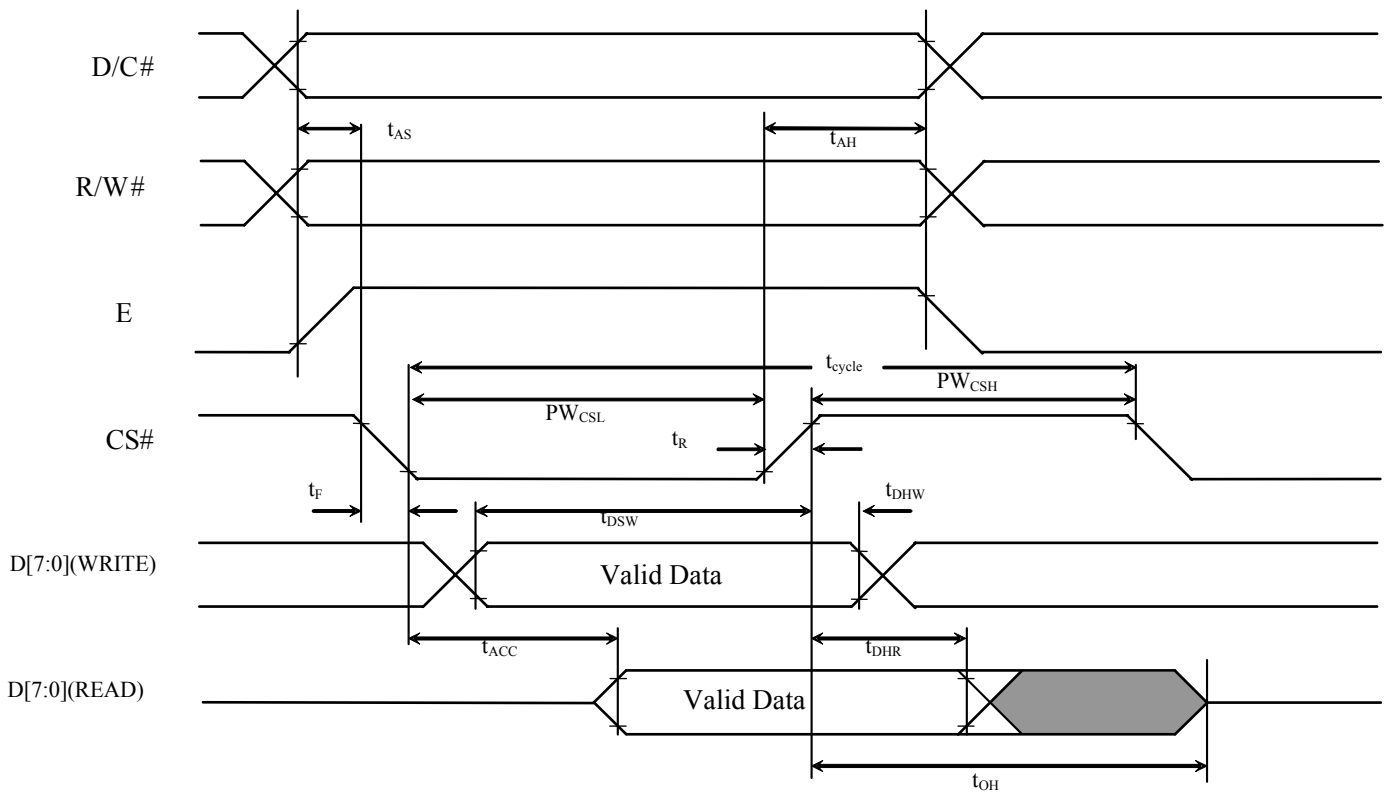

Table 13-3 : 8080-Series MCU Parallel Interface Timing Characteristics

($V_{DD} - V_{SS} = 2.4V$ to $3.5V$, $V_{DDIO} = V_{DD}$, $T_A = 25^\circ C$)

Symbol	Parameter	Min	Typ	Max	Unit
t_{cclk}	Clock Cycle Time	300	-	-	ns
t_{AS}	Address Setup Time	10	-	-	ns
t_{AH}	Address Hold Time	0	-	-	ns
t_{DSW}	Write Data Setup Time	40	-	-	ns
t_{DHW}	Write Data Hold Time	7	-	-	ns
t_{DHR}	Read Data Hold Time	20	-	-	ns
t_{OH}	Output Disable Time	-	-	70	ns
t_{ACC}	Access Time	-	-	140	ns
$t_{PWL R}$	Read Low Time	120	-	-	ns
$t_{PWL W}$	Write Low Time	60	-	-	ns
$t_{PWH R}$	Read High Time	60	-	-	ns
$t_{PWH W}$	Write High Time	60	-	-	ns
t_R	Rise Time	-	-	40	ns
t_F	Fall Time	-	-	40	ns
t_{CS}	Chip select setup time	0	-	-	ns
t_{CSH}	Chip select hold time to read signal	0	-	-	ns
t_{CSF}	Chip select hold time	20	-	-	ns

Figure 13-2 : 8080-series parallel interface characteristics (Form 1)

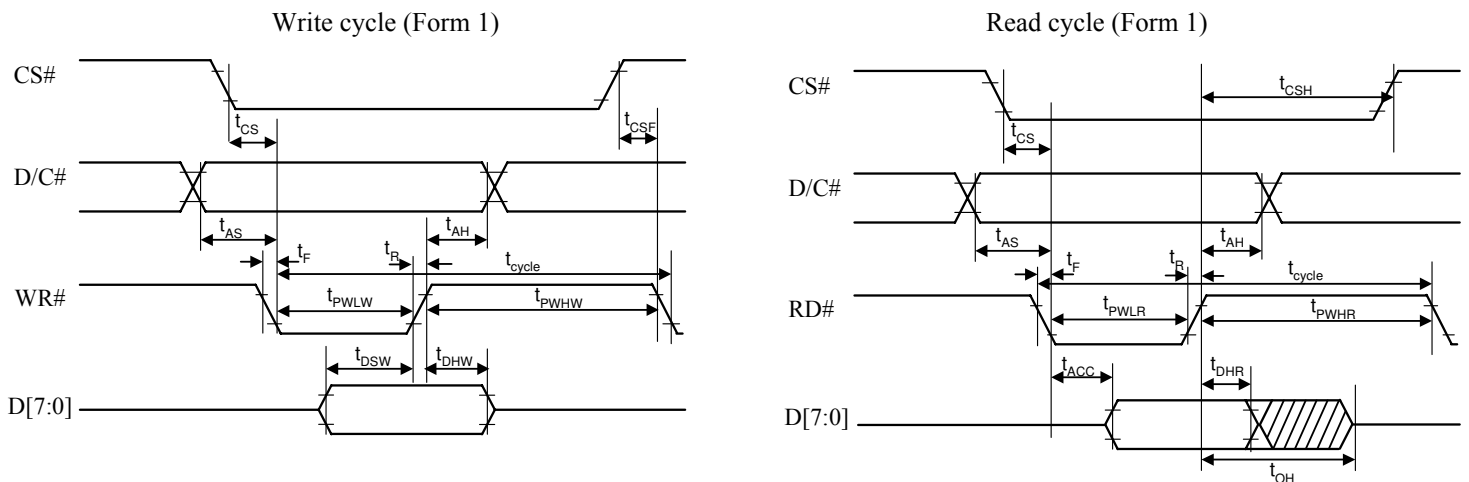

Figure 13-3 : 8080-series parallel interface characteristics (Form 2)

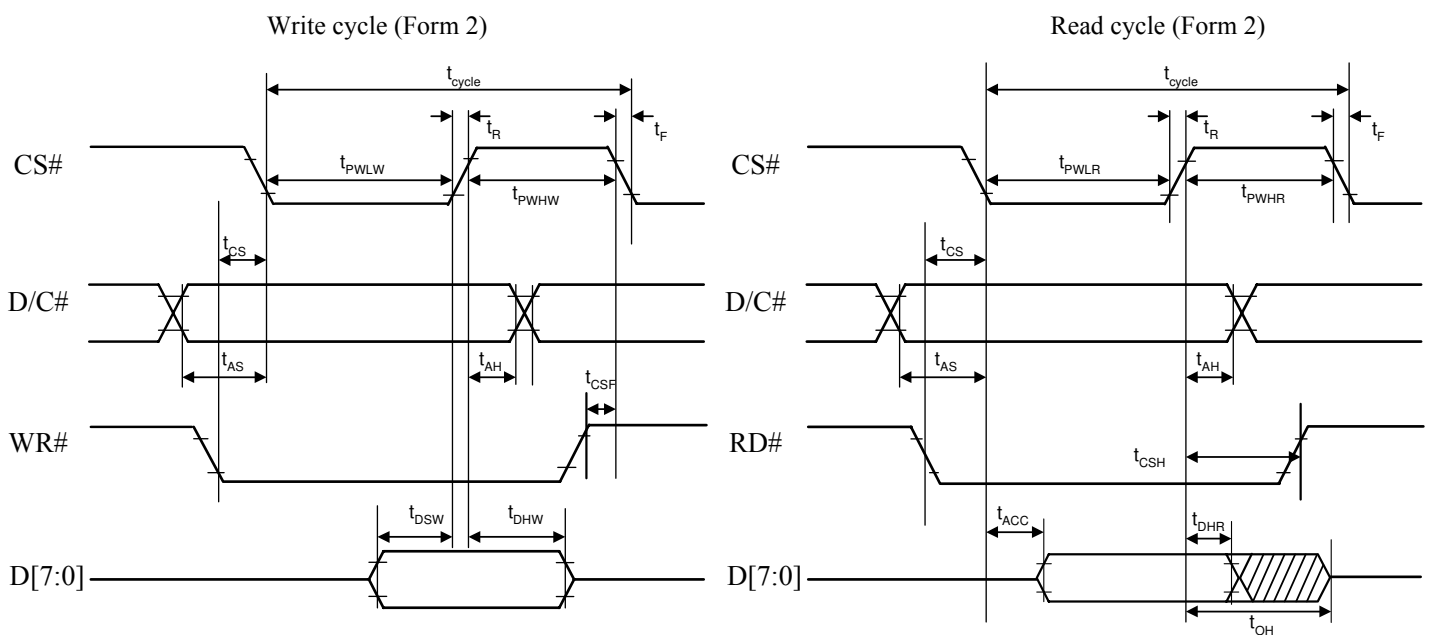
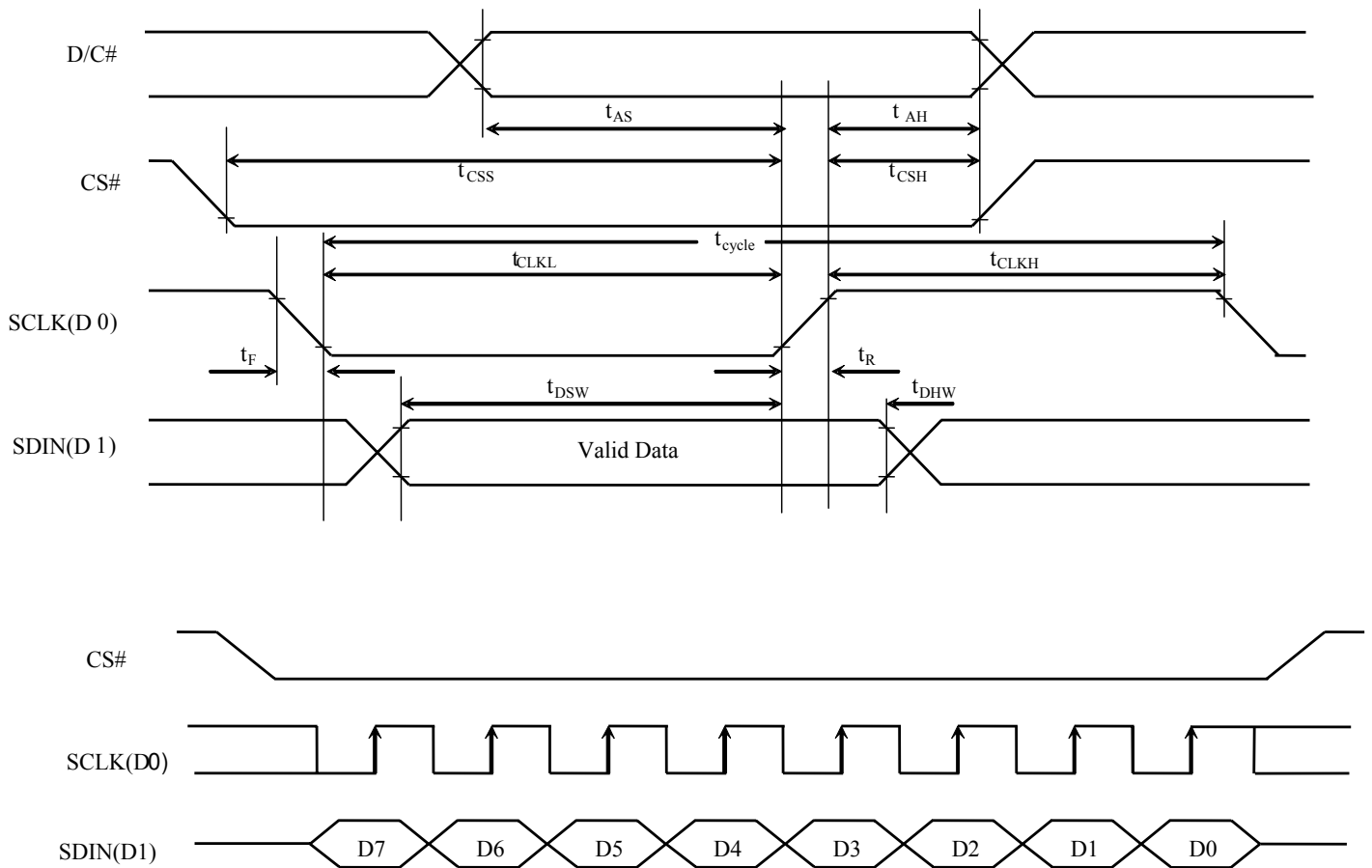

Table 13-4 : Serial Interface Timing Characteristics

($V_{DD} - V_{SS} = 2.4V$ to $3.5V$, $V_{DDIO} = V_{DD}$, $T_A = 25^\circ C$)

Symbol	Parameter	Min	Typ	Max	Unit
t_{cycle}	Clock Cycle Time	250	-	-	ns
t_{AS}	Address Setup Time	150	-	-	ns
t_{AH}	Address Hold Time	150	-	-	ns
t_{CSS}	Chip Select Setup Time	120	-	-	ns
t_{CSH}	Chip Select Hold Time	60	-	-	ns
t_{DSW}	Write Data Setup Time	50	-	-	ns </td
t_{DHW}	Write Data Hold Time	15	-	-	ns
t_{CLKL}	Clock Low Time	100	-	-	ns
t_{CLKH}	Clock High Time	100	-	-	ns
t_R	Rise Time	-	-	40	ns
t_F	Fall Time	-	-	40	ns

Figure 13-4 : Serial interface characteristics



Conditions:

$$V_{DD} - V_{SS} = 2.4 \text{ to } 3.5\text{V}$$

$$V_{DDIO} = V_{DD}$$

$$T_A = 25^\circ\text{C}$$

Table 13-5 :I²C Interface Timing Characteristics

Symbol	Parameter	Min	Typ	Max	Unit
t _{cycle}	Clock Cycle Time	2.5	-	-	us
t _{HSTART}	Start condition Hold Time	0.6	-	-	us
t _{HD}	Data Hold Time (for “SDA _{OUT} ” pin)	0	-	-	ns
	Data Hold Time (for “SDA _{IN} ” pin)	300	-	-	ns
t _{SD}	Data Setup Time	100	-	-	ns
t _{SSTART}	Start condition Setup Time (Only relevant for a repeated Start condition)	0.6	-	-	us
t _{SSTOP}	Stop condition Setup Time	0.6	-	-	us
t _R	Rise Time for data and clock pin	-	-	300	ns
t _F	Fall Time for data and clock pin	-	-	300	ns
t _{IDLE}	Idle Time before a new transmission can start	1.3	-	-	us

Figure 13-5 : I²C interface Timing characteristics

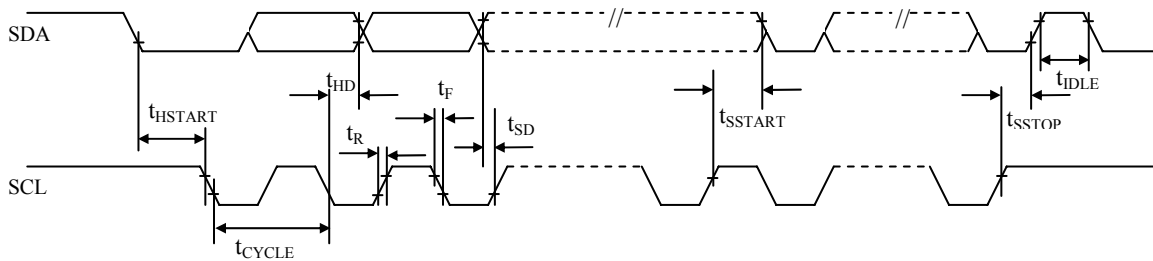

14 APPLICATION EXAMPLE

Figure 14-1 : Application Example of SSD1305T6R1

The configuration for 6800-parallel interface mode, external V_{CC} is shown in the following diagram:
 ($V_{DD}=2.7V$, $V_{CC}=12V$, $I_{REF}=10\mu A$)

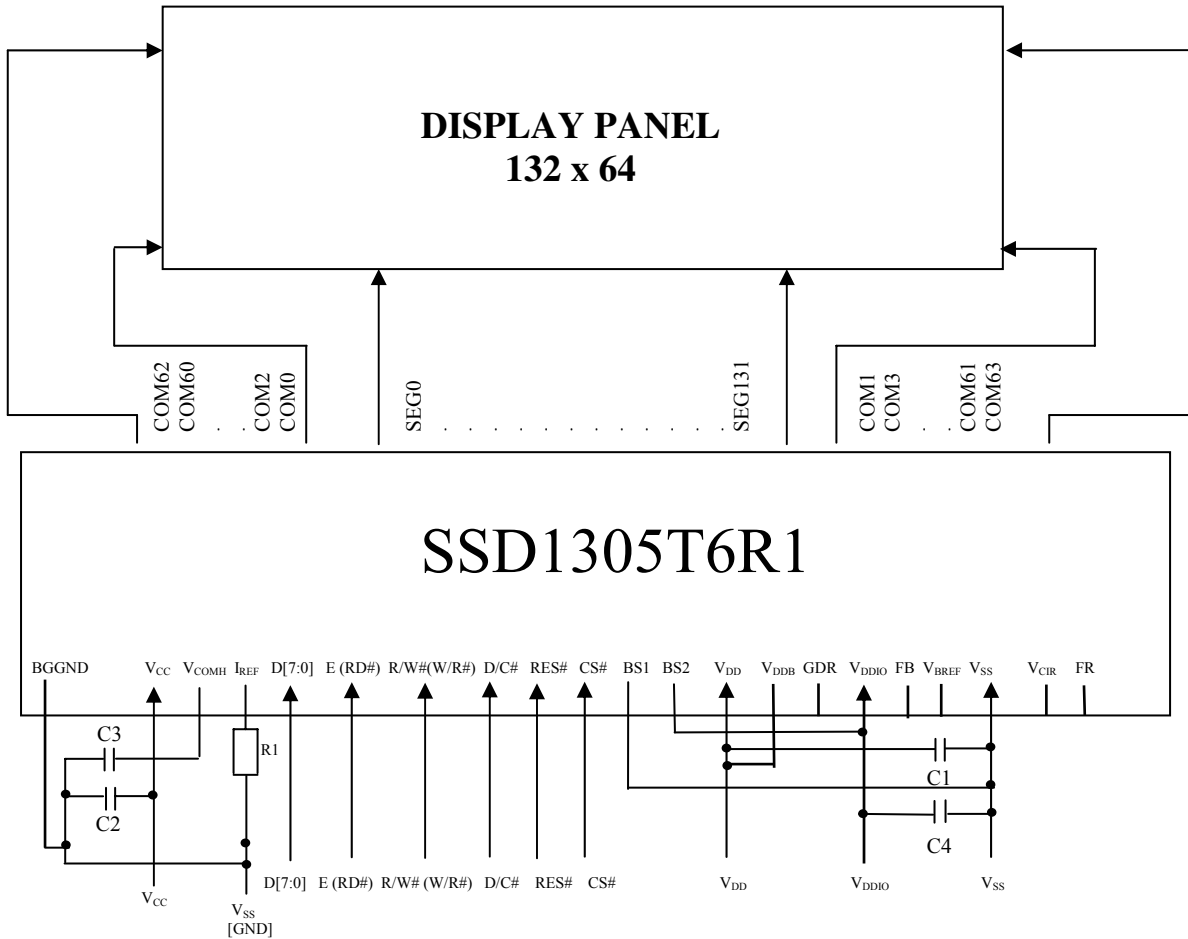

Pin connected to MCU interface: D[7:0], E, R/W#, D/C#, CS#, RES#

Pin internally connected to V_{SS} : BS0, V_{SSB}

GDR, V_{BREF} , FB should be left open if internal DC-DC converter is not used.

C1: 4.7 μF ⁽¹⁾

C2: 4.7 μF ⁽¹⁾

C3: 4.7 μF ⁽¹⁾

C4: 4.7 μF ⁽¹⁾

R1: 910k Ω , $R1 = (\text{Voltage at } I_{REF} \text{ pin} - V_{SS}) / I_{REF}$

Voltage at I_{REF} pin = $V_{CC} - 3V$

Note

⁽¹⁾ The capacitor value is recommended value. Select appropriate value against module application.

15 PACKAGE INFORMATION

15.1 SSD1305Z Die Tray Information

Figure 15-1 SSD1305Z die tray information

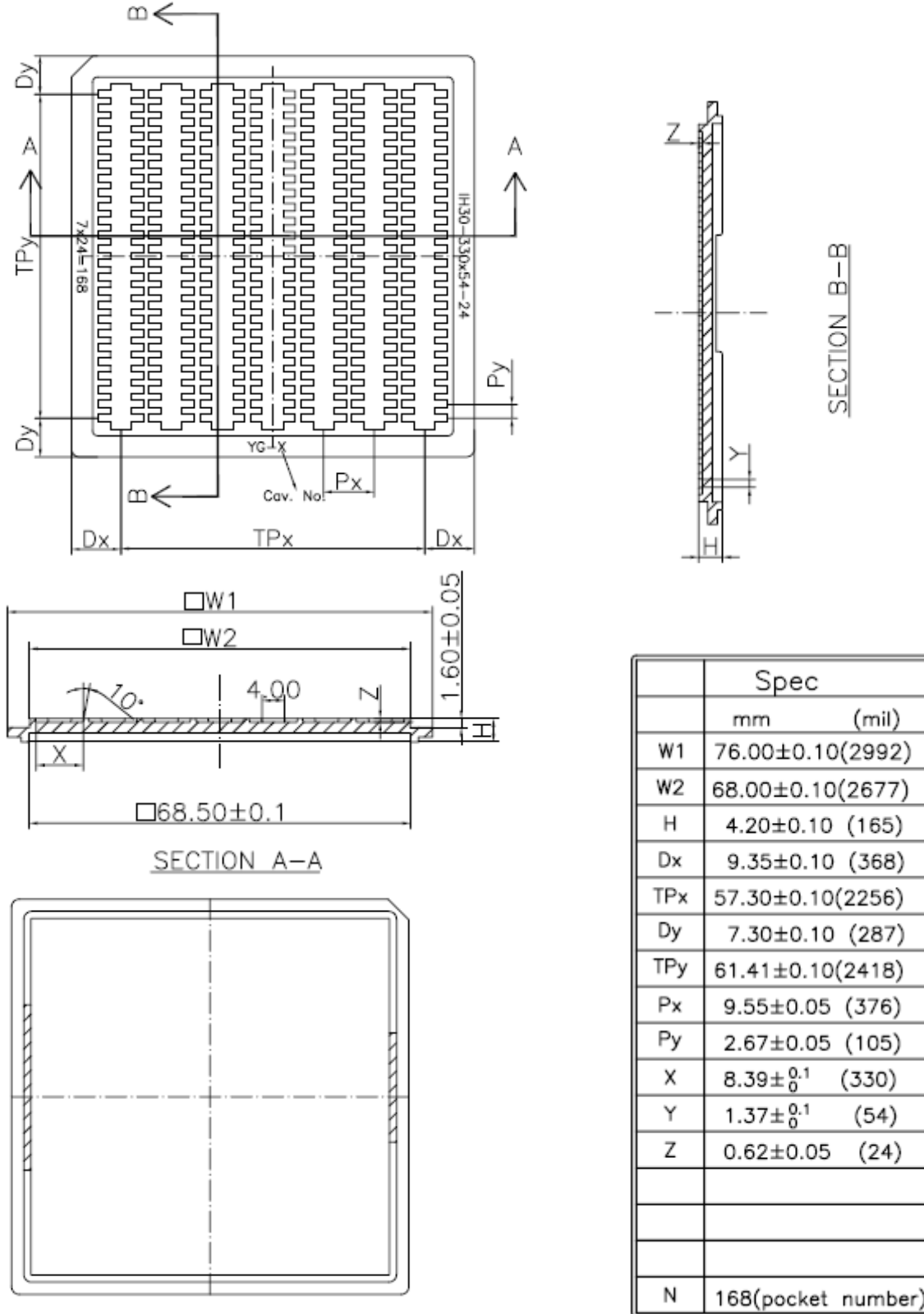

15.2 SSD1305T6R1 Detail Dimension

Figure 15-2 SSD1305T6R1 Detail Dimension

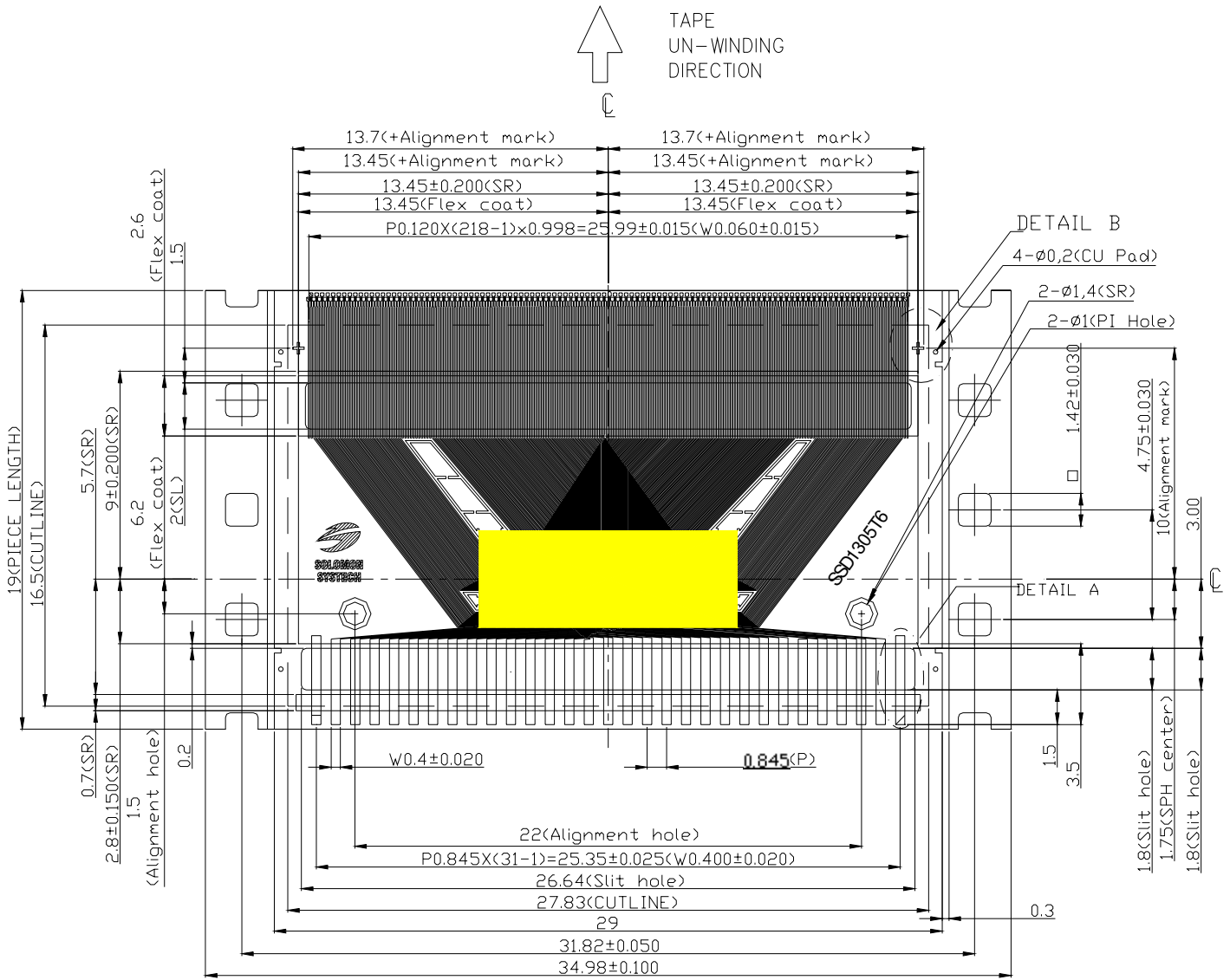

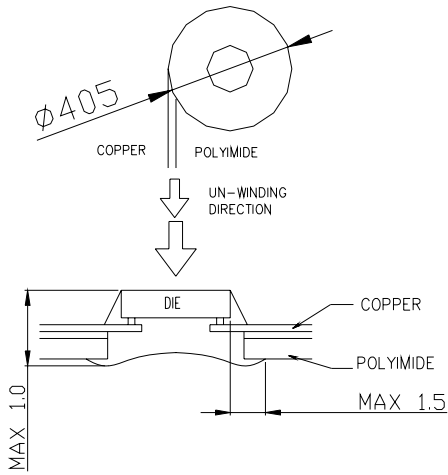

MIRROR DESIGN

NOTE:

1. GENERAL TOLERANCE: $\pm 0.05\text{MM}$
2. MATERIAL
 - PI: $75\pm 6\mu\text{m}$
 - Adhesive: $12\pm 2\mu\text{m}$ thickness
 - CU: $18\pm 5\mu\text{m}$
 - SR: $26\pm 14\mu\text{m}$
 - TOLERANCE ± 0.200
 - Flex coating :Min $10\mu\text{m}$
 - TOLERANCE ± 0.300
3. SN PLATING: $0.200\pm 0.05\mu\text{m}$
4. TAPESITE: 4 SPH, 19mm

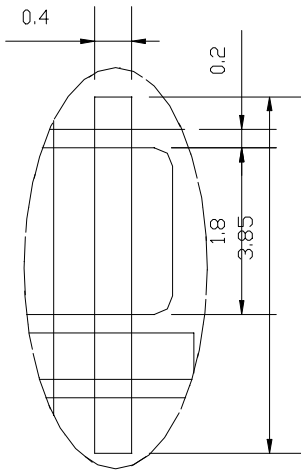

DETAIL A

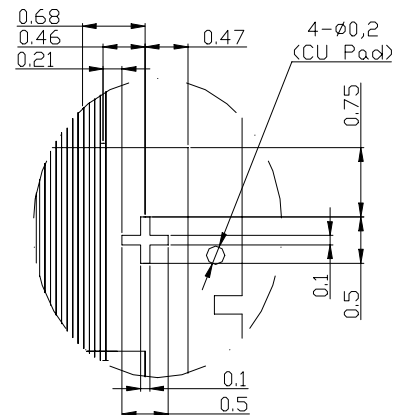

DETAIL B

Solomon Systech reserves the right to make changes without notice to any products herein. Solomon Systech makes no warranty, representation or guarantee regarding the suitability of its products for any particular purpose, nor does Solomon Systech assume any liability arising out of the application or use of any product or circuit, and specifically disclaims any, and all, liability, including without limitation consequential or incidental damages. “Typical” parameters can and do vary in different applications. All operating parameters, including “Typical” must be validated for each customer application by the customer’s technical experts. Solomon Systech does not convey any license under its patent rights nor the rights of others. Solomon Systech products are not designed, intended, or authorized for use as components in systems intended for surgical implant into the body, or other applications intended to support or sustain life, or for any other application in which the failure of the Solomon Systech product could create a situation where personal injury or death may occur. Should Buyer purchase or use Solomon Systech products for any such unintended or unauthorized application, Buyer shall indemnify and hold Solomon Systech and its offices, employees, subsidiaries, affiliates, and distributors harmless against all claims, costs, damages, and expenses, and reasonable attorney fees arising out of, directly or indirectly, any claim of personal injury or death associated with such unintended or unauthorized use, even if such claim alleges that Solomon Systech was negligent regarding the design or manufacture of the part.

All Solomon Systech Products complied with six (6) hazardous substances limitation requirement per European Union (EU) “Restriction of Hazardous Substance (RoHS) Directive (2002/95/EC)” and China standard “电子信息产品污染控制标识要求 (SJ/T11364-2006)” with control Marking Symbol . Hazardous Substances test report is available upon requested.

<http://www.solomon-systech.com>