

## Product Reference Manual

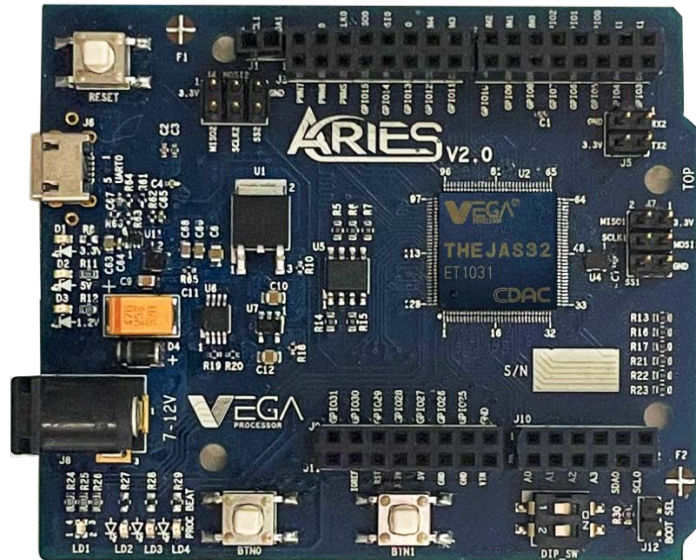

### Description

The ARIES v2.0 is a fully indigenous and a “Made in India” product to get started with basic microprocessor programming and embedded systems. This board is built upon a RISC-V ISA compliant VEGA Processor with easy-to-use hardware and software. The VEGA SDK also provides full ecosystem with numerous examples and support documentation. This board is designed and developed by Centre for Development of Advanced Computing (C-DAC) as part of the Digital India RISC-V (DIR-V) Program, by the Ministry of Electronics and Information Technology, Government of India.

### Target areas/Applications

Low power IoT, Sensor fusion, Smart Meter, System supervisors, Remote sensors, Wearable devices, Toy and electronic education equipment, Legacy 8/16-bit applications, Industrial networking and many more...

## Features

### Controller

**THEJAS32 SoC** with **VEGA ET1031** Microprocessor

### Memory

2MB Flash

256KB SRAM

### Peripherals

- PWM Pins : 8 nos
- Analog Input Pins : 4 nos
- SPI : 3 nos
- UART : 3 nos
- I2C : 2 nos
- GPIOs : 32 nos (23xGPIO, 2xDIP, 2xPB, 2xLEDs, 1xRGB LED)

### Clock Speed

Clock Speed : 100MHz

### Power

- Input Voltage : 7-12V
- DC Current per I/O Pin : 12 mA
- IO Voltage : 3.3 V

## CONTENTS

<b>1. The Board</b>	4
<b>2. Ratings</b>	4
2.1 Recommended Operating Conditions	4
2.2 Power Consumption	4
<b>3. Functional Overview</b>	4
3.1 Board Topology	4
3.2 Processor	5
3.3 THEJAS32 pinout	5
3.4 Power Tree	8
<b>4. Board Operation</b>	8
4.1 Getting Started	8
<b>5. Connector Pinouts</b>	9
5.1 Board Outline & Mounting Holes	12
<b>6. Company Information</b>	12
<b>7. Reference Documentation</b>	12

## 1. The Board

ARIES v2.0 is a development platform based on THEAS32 ASIC which operates at a frequency of 100MHz. THEAS32 SoC includes VEGA ET1031 Microprocessor, 256KB internal SRAM, Three UARTs, Four SPIs, Three TIMERS, Eight PWMs, Three I2C interfaces, 32 GPIOs etc. This board contains everything needed to support standalone operation. To get started simply connect the board to a computer with a Micro-B USB Cable or power it with a AC/DC adapter or a battery.

## 2. Ratings

### 2.1 Recommended Operating Conditions

Symbol	Description	Min	Max
	Conservative thermal limits for the whole board:	-0 °C (100°F)	85 °C ( 185°F)

### 2.2 Power Consumption

Symbol	Description	Min	Typ	Max	Unit
VINMax	Maximum input voltage from VIN pad	7	-	12	V
VUSBMax	Maximum input voltage from USB connector	-	5.5	V	
PMax	DC Current per I/O Pin	-	-	12	mA

## 3. Functional Overview

### 3.1 Board Topology

Top view

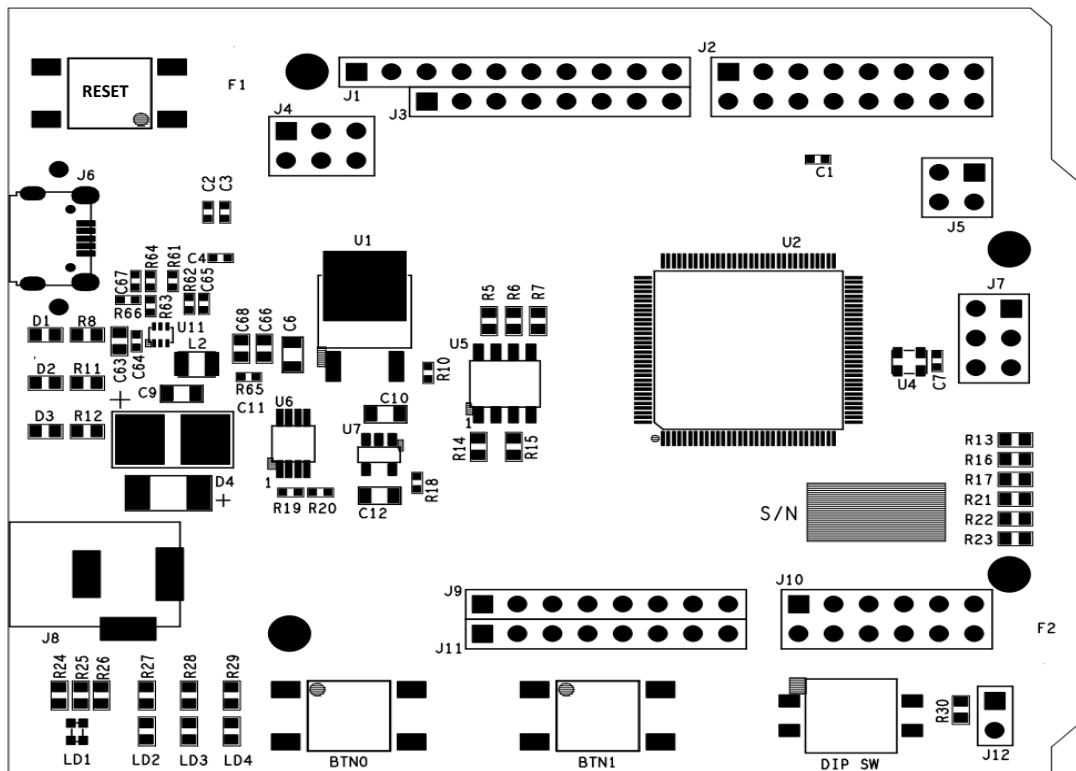

Ref.	Description	Ref.	Description
J8	Power jack	U2	THEJAS32 SoC
J6	USB B Connector	U1	3.3V Regulator
J12	Boot Select Header	U4	100 MHz Oscillator
RESET	Reset Button	U5	SPI Boot Flash Memory
BTN0	Push Button 0 for GPIO	U6	Op-amp
BTN1	Push Button 1 for GPIO	U7	1.2V Regulator
DIP_SW	DIP Switch for GPIO	LD1	RGB LED

### 3.2 Processor

The main controller is THEAJ32 SoC which operates at a frequency of 100MHz. It includes VEGA ET1031 Microprocessor, 256KB internal SRAM, Three UARTs, Four SPIs, Three TIMERS, Eight PWMs, Three I2C interface, 32 GPIOs. Most of its pins are connected to the external headers, however some are reserved for internal communication.

### 3.3 THEJAS32 pinout

Pin #	Pin Name	Pin Description
1	GPIO1(3)	General purpose IO.
2	GPIO1(2)	General purpose IO.
3	PVSSIOC23	Ground reference for IO pins.
4	PVDDIO23	Positive supply for IO pins. Connect to 3.3V supply.
5	GPIO1(1)	General purpose IO.
6	GPIO1(0)	General purpose IO.
7	SPI3MOSI	SPI 3 Master Out Slave In.
8	PVDDC18	Positive supply for logic. Connect to 1.2V supply.
9	PVSSC18	Ground reference for logic.
10	SPI3MISO	SPI 3 Master In Slave Out.
11	SPI3CLK	SPI 3 Clock.
12	SPI3CSN	SPI 3 Chip Select.
13	PVSSIOC21	Ground reference for IO pins.
14	PVDDIO21	Positive supply for IO pins. Connect to 3.3V supply.
15	BOOT	Boot select.
16	PROCBT	Heart beat signal.
17	TEDTUPD	Connect to GND.
18	PVDDC17	Positive supply for logic. Connect to 1.2V supply.
19	PVSSC17	Ground reference for logic.
20	TSTCLK	Connect to GND through a 1K resistor.
21	TJTAGTDO	JTAG TDO. Left unconnected.
22	TJTAGTMS	JTAG TMS. Connect to GND through a 1K resistor.
23	TJTAGTDI	JTAG TDI. Connect to GND through a 1K resistor.
24	PVSSIOC19	Ground reference for IO pins.
25	PVDDIO19	Positive supply for IO pins. Connect to 3.3V supply.
26	PVDDC16	Positive supply for logic. Connect to 1.2V supply.
27	PVSSC16	Ground reference for logic.
28	TJTAGTCK	JTAG TCK. Connect to GND through a 1K resistor
29	TJTAGTRST	JTAG TRST. Connect to GND through a 1K resistor
30	TSTMODE	Test mode select. Connect to GND through a 1K resistor.

31	IIC2SDA	I2C 2 Serial Data.
32	IIC2SCL	I2C 2 Serial Clock.
33	IIC0SCL	I2C 0 Serial Clock.
34	IIC0SDA	I2C 0 Serial Data.
35	PVSSC14	Ground reference for logic.
36	PVDDC14	Positive supply for logic. Connect to 1.2V supply.
37	PVDDIO17	Positive supply for IO pins. Connect to 3.3V supply.
38	PVSSIOC17	Ground reference for IO pins.
39	SPI1CSN	SPI 1 Chip Select.
40	SPI1CLK	SPI 1 Clock.
41	SPI1MISO	SPI 1 Master In Slave Out.
42	SPI1MOSI	SPI 1 Master Out Slave In.
43	RSTIN	Reset.
44	CLKSYS	System Clock.
45	URT1SOUT	UART 1 Serial Out / Transmit.
46	PVDDIO15	Positive supply for IO pins. Connect to 3.3V supply.
47	PVSSIOC15	Ground reference for IO pins.
48	PVSSC12	Ground reference for logic.
49	PVDDC12	Positive supply for logic. Connect to 1.2V supply.
50	URT1SIN	UART 1 Serial In / Receive.
51	GPIO0(15)	General purpose IO.
52	GPIO0(14)	General purpose IO.
53	GPIO0(13)	General purpose IO.
54	GPIO0(12)	General purpose IO.
55	GPIO0(11)	General purpose IO.
56	PVSSC11	Ground reference for logic.
57	PVDDC11	Positive supply for logic. Connect to 1.2V supply.
58	GPIO0(10)	General purpose IO.
59	PVDDIO13	Positive supply for IO pins. Connect to 3.3V supply.
60	PVSSIOC13	Ground reference for IO pins.
61	GPIO0(9)	General purpose IO.
62	GPIO0(8)	General purpose IO.
63	GPIO0(7)	General purpose IO.
64	GPIO0(6)	General purpose IO.
65	GPIO0(5)	General purpose IO.
66	GPIO0(4)	General purpose IO.
67	PVSSC9	Ground reference for logic.
68	PVDDC9	Positive supply for logic. Connect to 1.2V supply.
69	PVDDIO11	Positive supply for IO pins. Connect to 3.3V supply.
70	PVSSIOC11	Ground reference for IO pins.
71	GPIO0(3)	General purpose IO.
72	GPIO0(2)	General purpose IO.
73	GPIO0(1)	General purpose IO.
74	GPIO0(0)	General purpose IO.
75	PWM(7)	Pulse Width Modulation.
76	PWM(6)	Pulse Width Modulation.
77	PWM(5)	Pulse Width Modulation.
78	PVSSC7	Ground reference for logic.
79	PVDDC7	Positive supply for logic. Connect to 1.2V supply.

80	PWM(4)	Pulse Width Modulation.
81	PWM(3)	Pulse Width Modulation.
82	PWM(2)	Pulse Width Modulation.
83	PVDDIO8	IO Power Supply VDD pin.
84	PVSSIOC8	Ground reference for IO pins.
85	PWM(1)	Pulse Width Modulation.
86	PWM(0)	Pulse Width Modulation.
87	SPI0MOSI	SPI 0 Master Out Slave In.
88	PVSSC6	Ground reference for logic.
89	PVDDC6	Positive supply for logic. Connect to 1.2V supply.
90	SPI0MISO	SPI 0 Master In Slave Out.
91	SPI0CLK	SPI 0 Clock.
92	SPI0CSN	SPI 0 Chip Select.
93	PVDDIO6	Positive supply for IO pins. Connect to 3.3V supply.
94	PVSSIOC6	Ground reference for IO pins.
95	IIC1SDA	I2C 1 Serial Data.
96	IIC1SCL	I2C 1 Serial Clock.
97	SPI2MOSI	SPI 2 Master Out Slave In.
98	SPI2MISO	SPI 2 Master In Slave Out.
99	PVDDC4	Positive supply for logic. Connect to 1.2V supply.
100	PVSSC4	Ground reference for logic.
101	SPI2CLK	SPI 2 Clock.
102	SPI2CSN	SPI 2 Chip Select.
103	PVSSIOC4	Ground reference for IO pins.
104	PVDDIO4	Positive supply for IO pins. Connect to 3.3V supply.
105	URT2SIN	UART 2 Serial In / Receive.
106	URT2SOUT	UART 2 Serial Out / Transmit.
107	URT0SIN	UART 0 Serial In / Receive.
108	URT0SOUT	UART 0 Serial Out / Transmit.
109	GPIO1(15)	General purpose IO.
110	GPIO1(14)	General purpose IO.
111	GPIO1(13)	General purpose IO.
112	PVDDC2	Positive supply for logic. Connect to 1.2V supply.
113	PVSSC2	Ground reference for logic.
114	PVSSIOC2	Ground reference for IO pins.
115	PVDDIO2	Positive supply for IO pins. Connect to 3.3V supply.
116	GPIO1(12)	General purpose IO.
117	GPIO1(11)	General purpose IO.
118	GPIO1(10)	General purpose IO.
119	GPIO1(9)	General purpose IO.
120	GPIO1(8)	General purpose IO.
121	GPIO1(7)	General purpose IO.
122	GPIO1(6)	General purpose IO.
123	PVSSIOC0	Ground reference for IO pins.
124	PVDDIO0	Positive supply for IO pins. Connect to 3.3V supply.
125	PVDDC0	Positive supply for logic. Connect to 1.2V supply.
126	PVSSC0	Ground reference for logic.
127	GPIO1(5)	General purpose IO.
128	GPIO1(4)	General purpose IO.

### 3.4 Power Tree

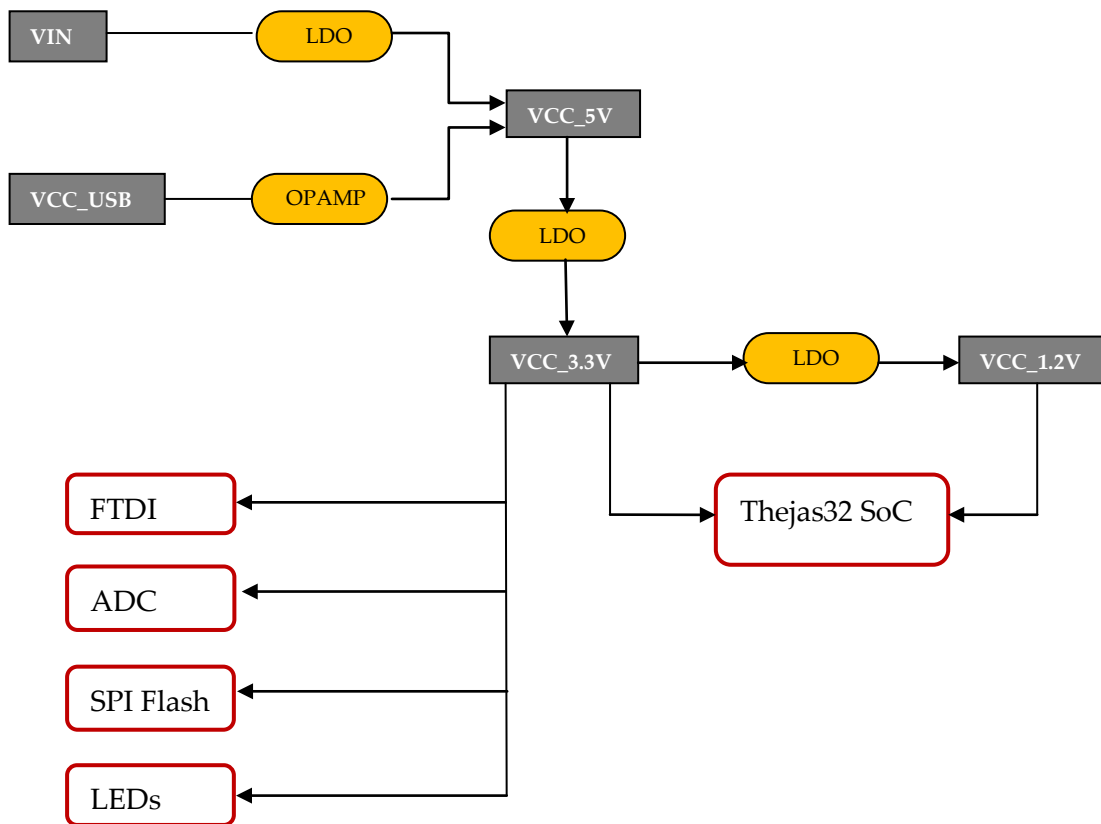

## 4. Board Operation

### 4.1 Getting Started

- To use Vega Arduino IDE for programming follow the steps given in the link below
  - For Linux; <https://bit.ly/vega-linux>
  - For Windows; <https://bit.ly/vega-windows>
- To use Eclipse IDE for programming follow the steps given in the link below
  - <https://cdac-vega.gitlab.io/sdkuserguide.html>



### 5. Connector Pinouts

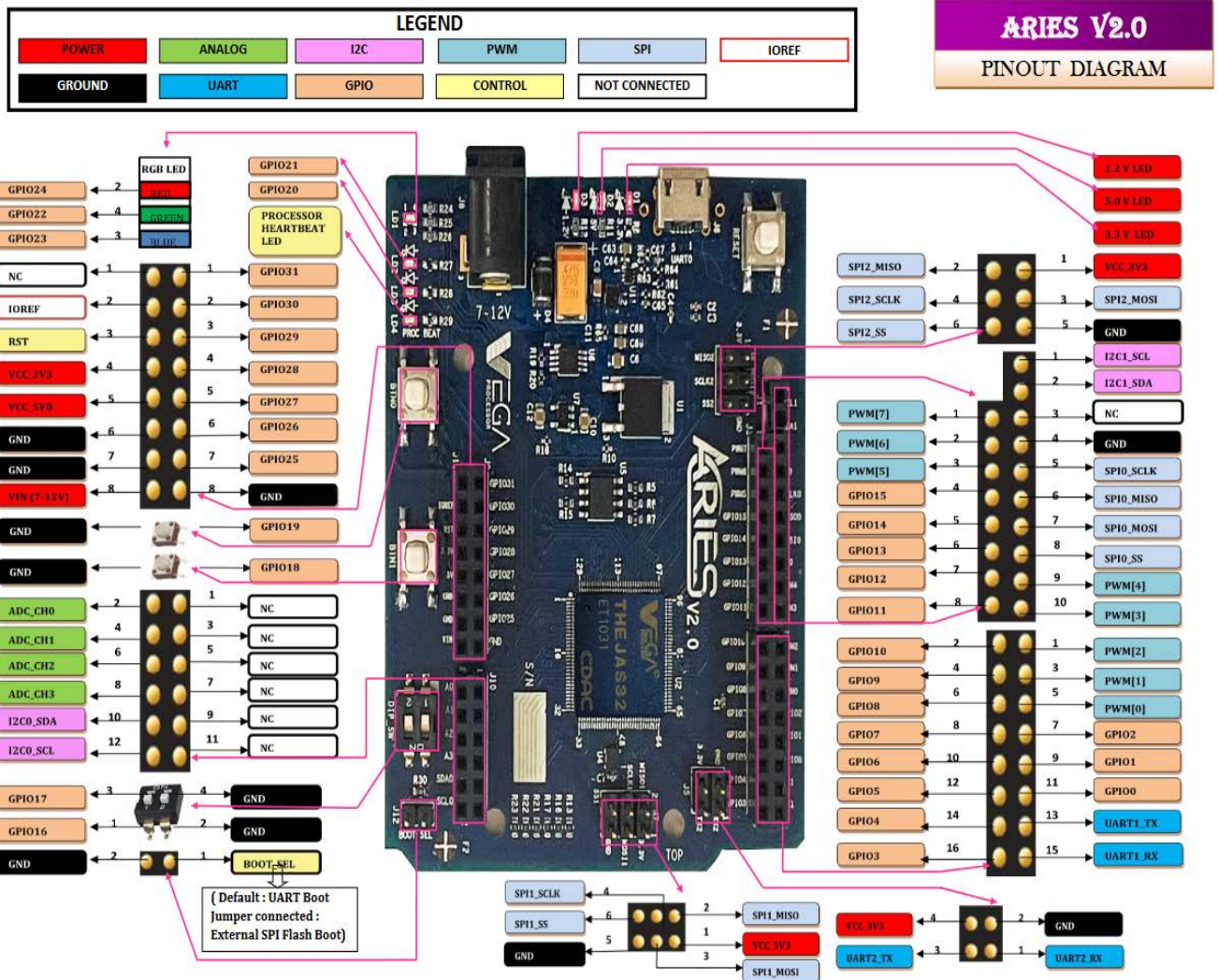

SL NO.	SPECIFICATIONS	THEJAS 32	ARIES BOARD	REMARKS
1	SPI (4)	SPI0_SS	J1_8	Connected to HEADER J1
2		SPI0_SCLK	J1_5	
3		SPI0_MISO	J1_6	
4		SPI0_MOSI	J1_7	
5		SPI1_SS	J7_6	Connected to HEADER J7
6		SPI1_SCLK	J7_4	
7		SPI1_MISO	J7_2	
8		SPI1_MOSI	J7_3	Connected to HEADER J4
9		SPI2_SS	J4_6	
10		SPI2_SCLK	J4_4	
11		SPI2_MISO	J4_2	
12		SPI2_MOSI	J4_3	Connected to SPI BOOT FLASH IC
13		SPI3_SS	U5_1	
14		SPI3_SCLK	U5_6	
15		SPI3_MISO	U5_2	
16		SPI3_MOSI	U5_5	
17	I2C (3)	SCL	J10_12	Connected to HEADER J10
18		SDA	J10_10	
19		SCL_1	J1_1	Connected to HEADER J1
20		SDA_1	J1_2	
21		SCL_2	U9_10	Connected to I2C ADC IC
22		SDA_2	U9_9	
23	UART (3)	UART0_RXD	U10_15	Connected to UART TO USB INTERFACE IC
24		UART0_TXD	U10_2	
25		UART1_RX	J2_15	Connected to HEADER J2
26		UART1_TX	J2_13	
27		UART2_RX	J5_1	Connected to HEADER J5
28		UART2_TX	J5_2	
29	PWM (8)	PWM[0]	J2_5	Connected to HEADER J2
30		PWM[1]	J2_3	
31		PWM[2]	J2_1	
32		PWM[3]	J1_10	Connected to HEADER J1
33		PWM[4]	J1_9	
34		PWM[5]	J3_3	Connected to HEADER J3
35		PWM[6]	J3_2	
36		PWM[7]	J3_1	
37	GPIO (32)	GPIO0	J2_11	Connected to HEADER J2
38		GPIO1	J2_9	
39		GPIO2	J2_7	
40		GPIO3	J2_16	
41		GPIO4	J2_14	
42		GPIO5	J2_12	
43		GPIO6	J2_10	

44		GPIO7	J2_8	
45		GPIO8	J2_6	
46		GPIO9	J2_4	
47		GPIO10	J2_2	
48		GPIO11	J3_8	Connected to HEADER J3
49		GPIO12	J3_7	
50		GPIO13	J3_6	
51		GPIO14	J3_5	
52		GPIO15	J3_4	
53		GPIO16	DIP_SW_1	Connected to DIP SWITCH
54		GPIO17	DIP_SW_3	
55		GPIO18	BTN1_1	Connected to PUSH BUTTON
56		GPIO19	BTN0_1	
57		GPIO20	LD3_1	Connected to LED
58		GPIO21	LD2_1	
59		GPIO22	LD1_4	Connected to GREEN of RGB LED
60		GPIO23	LD1_3	Connected to BLUE of RGB LED
61		GPIO24	LD1_2	Connected to RED of RGB LED
62		GPIO25	J9_7	Connected to HEADER J9
63		GPIO26	J9_6	
64		GPIO27	J9_5	
65		GPIO28	J9_4	
66		GPIO29	J9_3	
67		GPIO30	J9_2	
68		GPIO31	J9_1	
69	CLOCK	CLK_100M	U4_3	Connected to OSCILLATOR
70	RESET	PUSH_RESETN	U 8_1	Connected to RESET IC
71	HEART BEAT LED	PROC_HEART_BEAT	LD4_1	Connected to LED
72	BOOT SELECT	BOOT_SEL	J12_1	Connected to HEADER J12
73	ADC_CH0	-	J10_2 U9_4	ANALOG INPUTS Connected to HEADER J10 & I2C ADC IC
74	ADC_CH1	-	J10_4 U9_5	
75	ADC_CH2	-	J10_6 U9_6	
76	ADC_CH3	-	J10_8 U9_7	

### 5.1 Board Outline & Mounting Holes

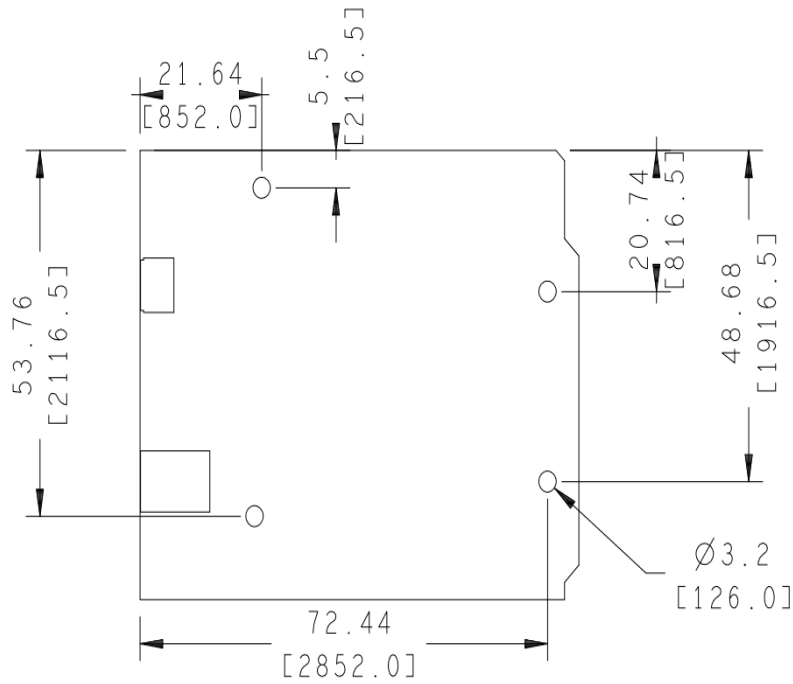

( Dimensions in mm[mil] )

### 6. Company Information

<b>Company name</b>	<b>C-DAC</b>
Company Address	Hardware Design Group Centre for Development of Advanced Computing (C-DAC) Thiruvananthapuram, Kerala – 695033 Fax: 0471-2723456 Email: <a href="mailto:vega@cdac.in">vega@cdac.in</a> <a href="http://www.vegaprocessors.in">www.vegaprocessors.in</a> <a href="http://www.cdac.in">www.cdac.in</a>

### 7. Reference Documentation

Reference	Link
ARIESv2.0 details	<a href="http://www.vegaprocessors.in/devboards/ariesv2">www.vegaprocessors.in/devboards/ariesv2</a>