

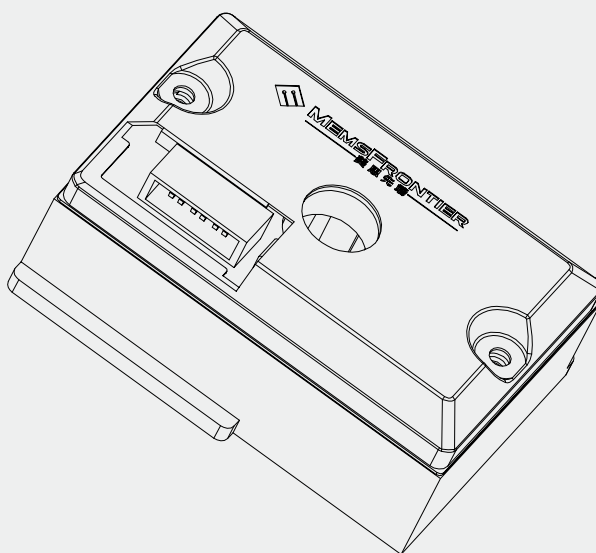

MEMSFRONTIER
美思先端

MPM30 SERIES

DUST SENSOR MODULE



Product Datasheet

S P E C I F I C A T I O N

Shenzhen MemsFrontier Electronics Co., Ltd.

MPM30 SERIES

DUST SENSOR MODULE

◆ APPEARANCE



◆ Product size

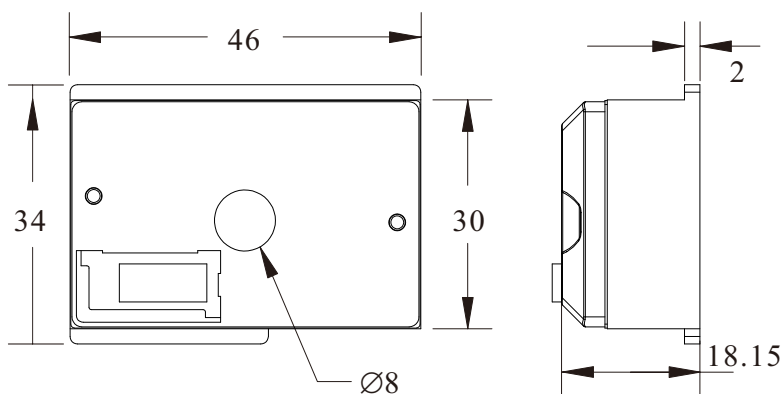

◆ Product parameters

Infrared PM sensor 30 series module	
Detection particle diameter	PM0.3~PM10
Detection concentration range	0~1000 μ g/m ³
Detection accuracy	$\pm 15\mu$ g/m ³ or $\pm 15\%$ reading (@25 $\pm 2^\circ$ C, 50% $\pm 10\%$ RH)
Power-on settling time	≤ 10 s
Working voltage	DC 5V $\pm 5\%$, Ripple below 50mV
Working current	≤ 15 mA
Output mode	UART/PWM
Interface	MPM30-C4: ZH1.5mm-4P socket MPM30-C6: ZH1.5mm-6P socket
Working conditions	-20 $^\circ$ C~+75 $^\circ$ C, 0~95%RH(non-condensing)
Storage conditions	-40 $^\circ$ C~+85 $^\circ$ C, 0~95%RH(non-condensing)
Lifespan	≥ 8 years
Dimensions	46 * 34 * 18.15mm (L \times W \times H)

MPM30 SERIES

DUST SENSOR MODULE

◆ Pin Definition

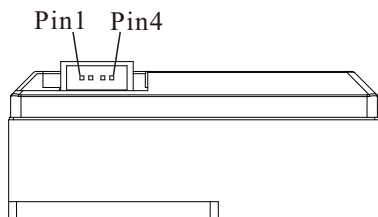

MPM30-C4

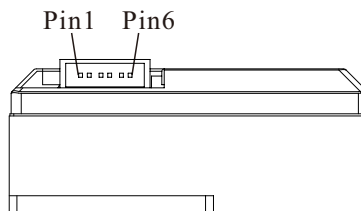

MPM30-C6

No.	Pin	Description	Electrical characteristics
Pin 1	GND	Power-	No reverse polarity protection
Pin 2	VCC	Power+(+5V)	
Pin 3	SET	UART baud rate setting pin. The module detects the level state of this pin within 1 second of power-up: if it is high (the pin is externally high or suspended), the UART baud rate is 9600bps.Low (pinged to GND), the UART baud rate is 2400bps.	TTL@3.3V Input (5V Compatible)
Pin 4	PWM	PWM pulse width signal output pin	Open output with an internal pull-up resistor connected to the positive supply
Pin 5	RXD	RXD pin of the module UART interface	TTL@3.3V Input (5V Compatible)
Pin 6	TXD	TXD pin of the module UART interface	Open output with an internal pull-up resistor connected to the positive supply

◆ Circuit connection

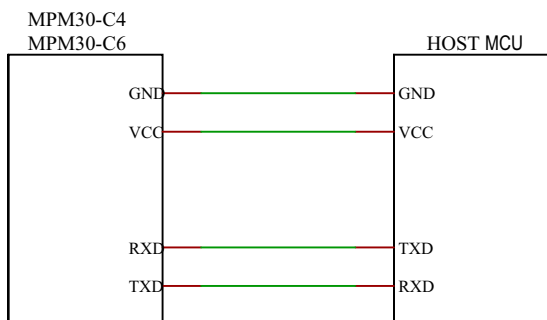

UART interface circuit connection (MPM30-C4/MPM30-C6)

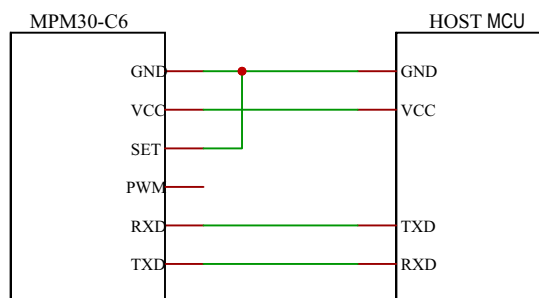

UART interface circuit connection (MPM30-C6 @2400bps)

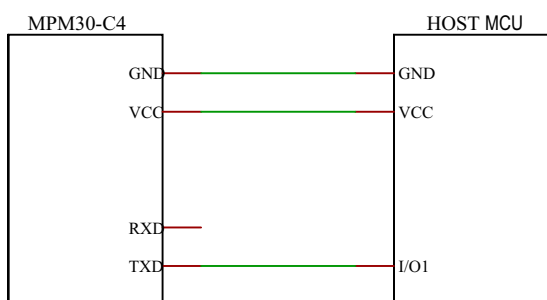

PWM Output circuit connection (MPM30-C4)

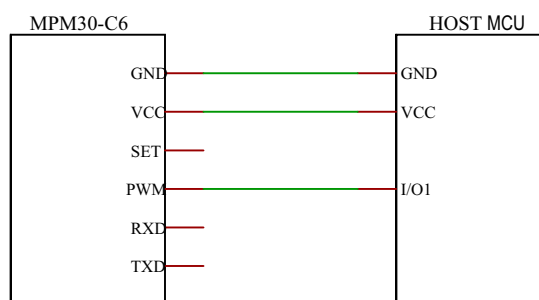

PWM Output circuit connection (MPM30-C6)

MPM30 SERIES DUST SENSOR MODULE

◆ Detection Principle

According to the principle of optical dispersion, the infrared light emitter is driven by the driving circuit to emit a pulsed infrared beam, the beam is scattered on the suspended particles in the air after the lens is converged, and the scattered light is received by the infrared photoelectric receiver after the lens is converged, converted into an electrical pulse signal, and the intensity of the pulse signal is proportional to the concentration of the particles, and the concentration of the dust can be judged according to the intensity of this pulse signal. The signal is amplified by the amplifier and fed into the microprocessor for calculation and processing, and the detection result data is output from the communication interface of the microprocessor.

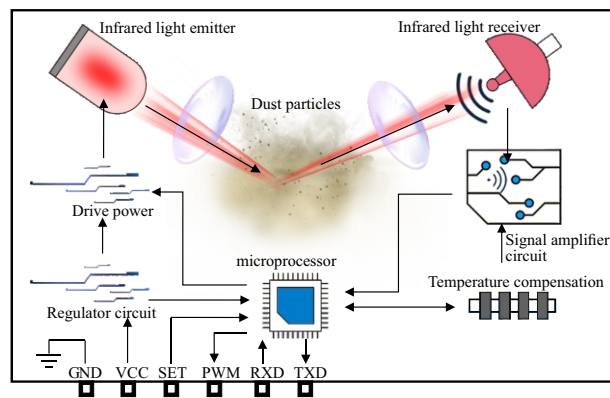

◆ Installation Mode

Two mounting options are available:

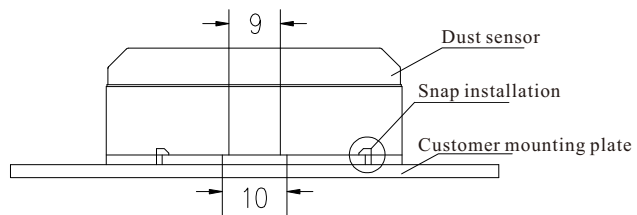
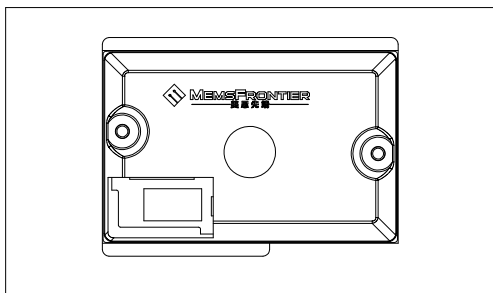

Snap installation

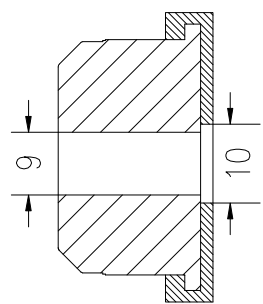
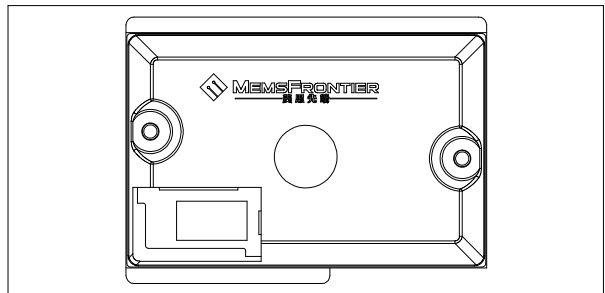

Card slot installation

It is recommended that the module terminals face down when installing;
Note that the vents of the module should have airflow through;

Recommended installation orientation:

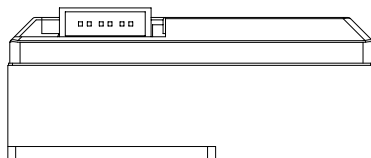
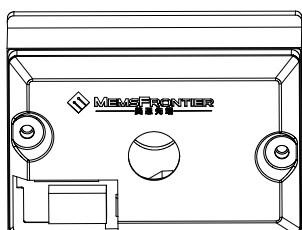

MPM30 SERIES

DUST SENSOR MODULE

◆ Installation precautions

1. The module should be installed in the position of air circulation to maintain ventilation in the air intake;
2. The module is installed in the backlight as much as possible to prevent external light from entering the module from the ventilation hole, causing the module error to increase;
3. The module housing is of conductive material and is connected to the circuit GND to prevent the module GND pins from being connected to the system above the safety voltage of the human body;
4. Avoid contact with organic solvents and do not use in environments of organic gases and combustible gases;
5. The module avoids contact with water mist, which will cause abnormal fluctuations in the module data;
6. The module is severely shaken and the measurement error will increase;
7. The module is as far away from the high-frequency high-voltage generating source strong electromagnetic environment as possible to prevent interference with the module.

◆ Communication Protocol A

Communication protocol A is only available for MPM30-C6. Communication protocol A includes UART serial communication and PWM communication, and the two communication methods can be used at the same time.

UART serial communication:

UART serial port settings	baud rate	Data bits	Stop bit	Checksum	Interface level
The SET pin is high	9600bps	8 bits	1 bit	N/A	5V
The SET pin is low	2400bps	8 bits	1 bit	N/A	5V

The module detects the level state of the SET pin at power-up: if it is high (the pin is externally high or dangling), the UART baud rate is 9600bps. Low (pinged to GND), the UART baud rate is 2400bps.

Serial output is divided into two states: automatic output and passive output. The default state of the module after power-up is automatic output, that is, the module actively sends serial data to the host at an interval of 1sec. The host MCU can send instructions to make the module switch to passive output mode, and when the passive output is initiated by the host MCU, the query module responds to the output data once.

Serial output data format: AA X1 X2 X3 X4 X5 FF

Feature bytes: The 1st byte AA and the last byte FF are fixed values. Data bytes: X1 to X4 total 4 bytes, where X1, X2 are particle measurements, and other bytes are retained. Check byte: X5 is the check byte. A low byte that is the sum of X1 to X4. Data conversion formula: Concentration value = X1×256 + X2 For example, the serial output data is: AA 01 0E 00 00 B9 FF, then the concentration value = 1×256 + 14 = 270 ug/m³

Output Mode Switching Instructions: Switch to Passive Output Mode Instructions: 5A 00 00 00 04 A6 80 01 01 28
Switch to Automatic Output Mode Instructions: 5A 00 00 00 04 A6 80 01 00 27 The module receives an instruction and responds to output data once. After the output mode is changed, the module can be powered down and saved.

PWM Communications

The cycle of PWM is 2000ms
 PWM range: 1~ 1000 (ug/m³)
 RMS potential: Low potential
 Minimum low time 1ms

The calculation formula for obtaining the current concentration value by PWM:

$$\text{Concentration value (ug/m}^3\text{)} = 2000 * (\text{TL}) / (\text{TH} + \text{TL})$$

TL is the time in an output cycle when the output is low

TH is the time in an output cycle when the output is high

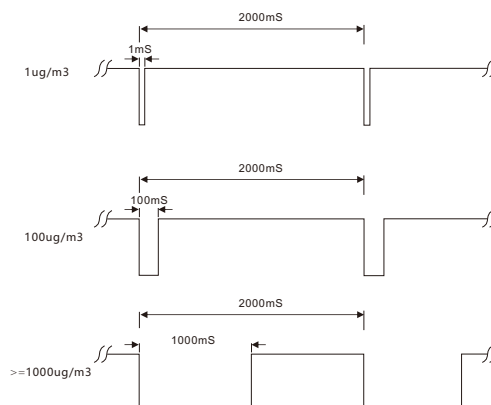

MPM30 SERIES

DUST SENSOR MODULE

◆ Communication Protocol B

Communication protocol B is only available for MPM30-C4.

Communication protocol B includes UART serial port communication and PWM communication, the two communication methods are enabled in the following ways.

Within 5 seconds after the module is powered on, RXD receives a valid serial port command (such as a host read instruction) and enables the serial port communication mode. If no valid instruction is received within 5 seconds, it is true PWM output mode, where the PWM signal is output from the module's TXD pin.

Serial communication

UART serial port settings	baud rate	Data bits	Stop bit	Checksum	Interface level
	9600bps	8bit	1 bit	N/A	5V

In the serial port communication mode, the module does not actively upload data, requiring the host to send data reading instructions, and the module answers the output detection data.

After decoding the serial port data, the particle concentration value is obtained in ug/m3.

Host read instruction: 11 02 0B 01 E1

Module answer data: 16 11 0B X1 X2 X3 X4 X5 X6 X7 X8 X9 X10 X11 X12 X13 X14 X15 X16

The reply data contains

Feature bytes: The first 3 bytes are fixed values: 16 11 0B.

Data bytes: X1~X15 have a total of 15 bytes, of which X3 and X4 are particle measurements; other bytes are retained.

Check bytes: X16 is the check byte padding. The low byte of the sum of all 19 bytes of the module reply data is 0x00 the validation is successful, not for 0x00, validation fails.

Data conversion formula:

$$\text{Concentration value} = X3 \times 256 + X4$$

For example, the response data is: 16 11 0B 00 00 01 04 05 06 07 08 09 0A 0B 0C 0D 0E 0F 5B

Then, the concentration value = $1 \times 256 + 4 = 260 \text{ ug/m}^3$

PWM Communications

The cycle of PWM is 1000ms

PWM range: 0~992(ug/m3)

RMS potential: Low potential

The start phase outputs 4ms low

The middle period is 992ms

The end phase outputs 4ms high

The calculation formula for obtaining the current concentration value by PWM:

$$\text{Concentration value (ug/m}^3\text{)} = 1000 \cdot (\text{TL} - 4\text{ms}) / (\text{TH} + \text{TL})$$

TH is the time in an output cycle when the output is high

TL is the time in an output cycle when the output is low

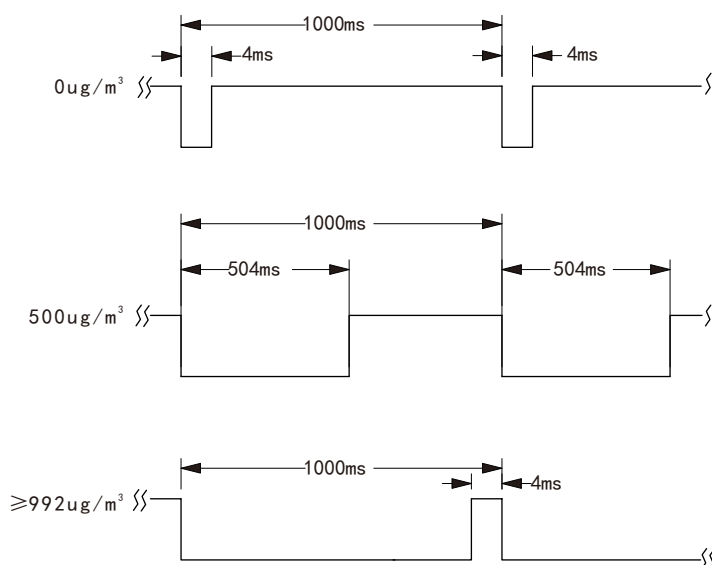

MPM30 SERIES

DUST SENSOR MODULE

◆ Communication protocol C

Communication protocol C is only available for MPM30-C4. Communication protocol C contains UART serial port communication.

Serial communication

UART serial port settings	Baud rate	Data bits	Stop bit	Checksum	Interface level
	9600bps	8bit	1bit	N/A	5V

The module is continuous operation by default, the UART serial port automatically uploads the detection data every 1 second, and the host only needs to receive the detection data during the application process, and the received serial port data is decoded to obtain the particle concentration value, the unit is ug/m3.

The serial port outputs a frame of data consisting of 4 bytes, and the data format is as follows:

Characteristic byte	Data byte 1	Data byte 2	Check byte
0xA5	DATAH	DATAL	SUM

Characteristic byte: fixed value 0xA5.

Data byte: DATAH is the upper 7 bits of the density value, DATAL is the lower 7 bits of the density value.

Check Byte: The lower 7 bits of the cumulative sum of all bytes before the check byte.

Serial port data conversion formula:

$$\text{Concentration value} = \text{DATAH}(\text{bit}[6:0]) \times 128 + \text{DATAL}(\text{bit}[6:0])$$

For example, the serial port outputs 4 bytes of data: 0xA5 0x01 0x2C 0x52 Then,

$$\text{DATAH} = 0x01 = 1, \text{DATAL} = 0x2C = 44,$$

$$\text{concentration value} = 1 \times 128 + 44 = 172 \text{ ug/m}^3$$

◆ Version history

Date	Version	Update
2022.3.29	1.00	Initial version