

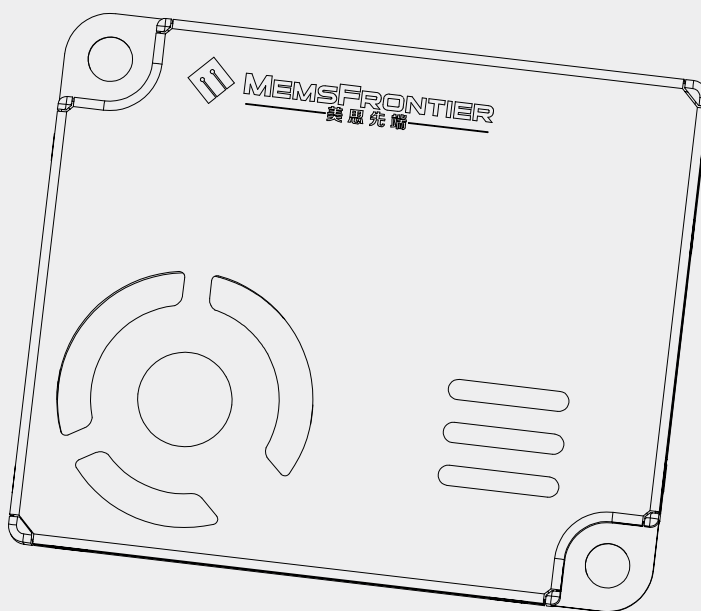

**MEMSFRONTIER**  
美思先端

# MPM12-BG

Air Laser Particulate Matter Sensor



S P E C I F I C A T I O N

Shenzhen MemsFrontier Electronics Co., Ltd.

# MPM12-BG

Air Laser Particulate Matter Sensor

## ◆ Product appearance and size

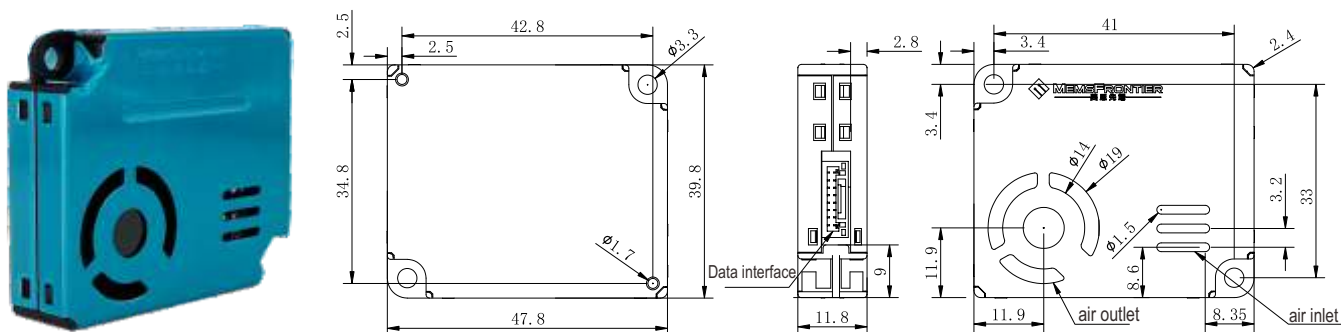

## ◆ Product parameters

parameters	index	unit
Types of particle detection	PM1.0, PM2.5, PM10	
Particle detection diameter range	0.3-10 $\mu$ m	$\mu$ m
Particulate matter concentration range (PM2.5 standard value)	0~1000 $\mu$ g/m <sup>3</sup>	$\mu$ g/m <sup>3</sup>
Particle Mass Concentration Resolution	1 $\mu$ g/m <sup>3</sup>	$\mu$ g/m <sup>3</sup>
Consistency of particulate matter concentration (PM2.5 standard value) *Note	$\pm 10\%$ (@100~500 $\mu$ g/m <sup>3</sup> ) $\pm 10\mu$ g/m <sup>3</sup> (@ 0~100 $\mu$ g/m <sup>3</sup> )	$\mu$ g/m <sup>3</sup>
single response time	$\leq 1$ s	s
Comprehensive response time	$\leq 10$ s	s
DC supply voltage	5.0V	V
Working current	$\leq 85$ mA	mA
Stand-by current	$\leq 45\mu$ A	$\mu$ A
<b>Data interface level</b>	L < 0.8 (@3.3); H > 2.7(@3.3)	V
Storage temperature	-30 $^{\circ}$ C ~ +70 $^{\circ}$ C	$^{\circ}$ C
Range of working temperature	-10 $^{\circ}$ C ~ +60 $^{\circ}$ C	$^{\circ}$ C
Working humidity range	0~99%RH(no condensation)	
Mean time between failures	$\geq 5$ Years	Year
Dimensions	47.8*39.8*11.8mm(L×W×H)	mm

Note: The particle concentration consistency data is data 2 in the communication protocol (test conditions: 25 $\pm$ 2 $^{\circ}$ C, 50 $\pm$ 10%RH).

# MPM12-BG

Air Laser Particulate Matter Sensor

## ◆ Pin Diagram

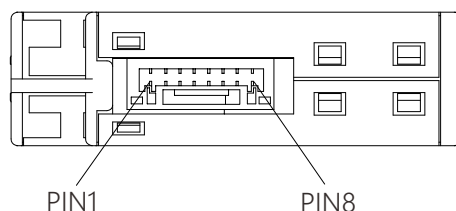

Pin number	Pin name definition	Pin function description	Pin Electrical Characteristics
Pin 1	VCC	Positive power supply (+5V)	No reverse polarity protection
Pin 2	GND	Power supply negative (-5V)	
Pin 3	SET	Set the module to work normally or sleep. High level or floating: the module works normally, low level: the module sleeps.	TTL level@3.3V; input pin with internal pull-up resistor.
Pin 4	RXD/SDA	RX of the UART interface of the module, or SDA of the IIC interface. Usually connected to the TX of the UART interface of the client MCU, or the SDA of the IIC interface.	TTL level@3.3V; external pull-up resistor is required when used as IIC function.
Pin 5	TXD/SCL	TX of module UART interface, or SCL of IIC interface. Usually connected to RX of UART interface of client MCU, or SCL of IIC interface.	TTL level@3.3V; external pull-up resistor is required when used as IIC function.
Pin6	RESET	Module reset signal input pin. Low level reset; should be left open when not in use.	TTL level@3.3V; input pin with internal pull-up resistor.
Pin7	PWM/SEL	The PWM output pin (active low) is also the selection pin of the UART or IIC communication interface. The module detects the level state of this pin within 1 second when it is powered on: it is high level (the pin is externally pulled up or left floating): the pin is used as a PWM signal output pin, and the UART interface is available (I IC interface cannot be used) use). It is low level (pin is connected to GND): the pin has no PWM output function, and the IIC communication interface is available (the UART interface is not available)	TTL level@3.3V; push-pull output mode when used as PWM output pin.
Pin 8	N/C	This pin is left open	

## ◆ circuit connection

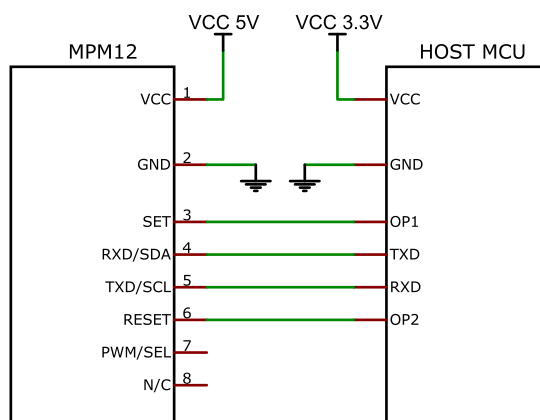

## MPM12-BG

### Air Laser Particulate Matter Sensor

Circuit design should pay attention to:

1. The power supply voltage of the MPM12-BG module is 5V. The data communication and control pins are both 3.3V as high level, so the mainboard MCU connected to communicate should be powered by 3.3V. If the main board MCU is powered by 5V, a level conversion chip or circuit should be added to the communication lines (RXD, TXD) and control lines (SET, RESET).
2. SET and RESET have internal pull-up resistors, if not used, they should be left floating.
3. Attention should be paid when applying the hibernation function: the fan stops working during hibernation, and it takes at least 30 seconds to stabilize the fan to restart. Therefore, in order to obtain accurate data, the working time of the module after hibernation and waking up should not be less than 30 seconds.

### ◆ Working principle.

According to the principle of laser scattering, the laser beam emitted by the laser irradiates the suspended particles in the air to generate scattering, and the laser photoelectric receiver is placed at a specific position to collect the scattered light, and the curve of the scattered light intensity with time is obtained. Microprocessing collects the electrical signal of the receiver in real time, and uses the algorithm based on Mie theory to obtain the equivalent particle size of the particles and the number of particles with different particle sizes per unit volume. The functional block diagram of the sensor is shown in the following figure.

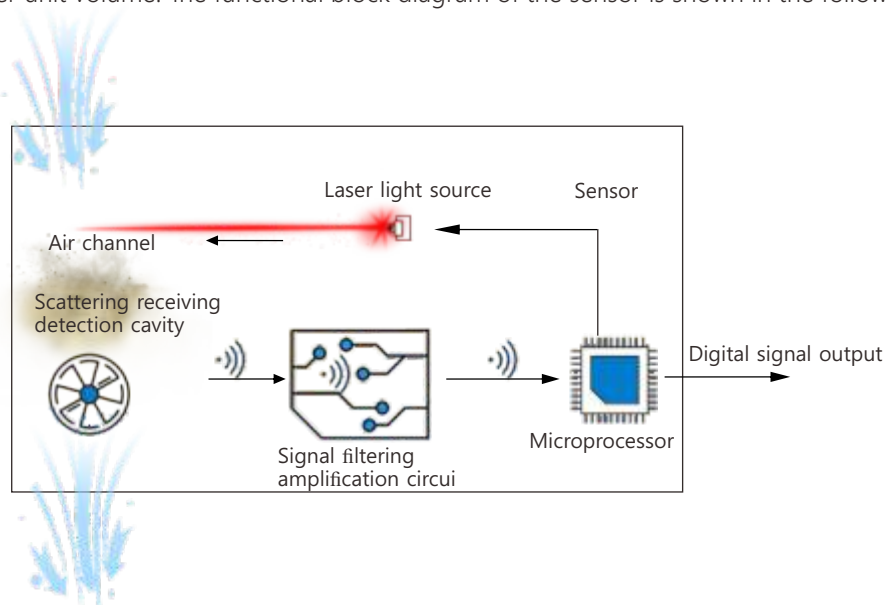

### ◆ Serial communication protocol

Serial output is divided into two states: automatic output and passive output. After the module is powered on, the default state is automatic output, that is, the module actively sends serial data to the host, and the time interval is 1sec. The host MCU can send commands to turn the module into passive output mode, and the host MCU initiates a query command for passive output, and the module responds to a query and outputs data once.

Default baud rate: 9600bps Check bit: none Stop bit: 1 bit, total data length: 32 bytes.

Serial port automatic output data format:

Number	byte	Numerical value	Descriptions
1	starter 1	0x42	(fixed)
2	starter 2	0x4d	(fixed)
3	Frame length high byte	**	Frame length=2x13+2(data+check digit)
4	Frame length low byte	**	
5	Data 1 high byte	**	PM1.0 concentration value (standard particulate matter), unit $\mu\text{g}/\text{m}^3$ *
6	Data 1 low byte	**	
7	Data 2 high byte	**	PM2.5 concentration value (standard particulate matter), unit $\mu\text{g}/\text{m}^3$ *
8	Data 2 low byte	**	
9	Data 3 high byte	**	Pm10 concentration value (standard particulate matter), unit $\mu\text{g}/\text{m}^3$ *
10	Data 3 low byte	**	

# MPM12-BG

## Air Laser Particulate Matter Sensor

Number	byte	Numerical value	Descriptions
11	Data 4 high byte	**	PM1.0 concentration value (in atmospheric environment), unit $\mu\text{g}/\text{m}^3$ *
12	Data 4 low byte	**	
13	Data 5 high byte	**	PM2.5 concentration value (in atmospheric environment), unit $\mu\text{g}/\text{m}^3$ *
14	Data 5 low byte	**	
15	Data 6 high byte	**	Pm10 concentration value (in atmospheric environment), unit $\mu\text{g}/\text{m}^3$ *
16	Data 6 low byte	**	
17	Data 7 high byte	**	The number of particles with a diameter of more than 0.3um in 0.1 liter of air
18	Data 7 low byte	**	
19	Data 8 high byte	**	The number of particles with a diameter of more than 0.5um in 0.1 liter of air
20	Data 8 low byte	**	
21	Data 9 high byte	**	The number of particles with a diameter of more than 1.0um in 0.1 liter of air
22	Data 9 low byte	**	
23	Data 10 high byte	**	The number of particles with a diameter of more than 2.5um in 0.1 liter of air
24	Data 10 low byte	**	
25	Data 11 high byte	**	The number of particles with a diameter of more than 5.0um in 0.1 liter of air
26	Data 11 low byte	**	
27	Data 12 high byte	**	The number of particles with a diameter of more than 10um in 0.1 liter of air
28	Data 12 low byte	**	
29	Data 13 high byte	**	reserve
30	Data 13 low byte	**	reserve
31	Data and parity high byte	**	Check code = frame header byte 1 + frame header byte 2 + ... + data 13 low byte
32	Data and parity low byte	**	

Note: The standard particle mass concentration value refers to the mass concentration value obtained by using industrial metal particles as equivalent particles for density conversion, which is suitable for industrial production workshops and other environments. The mass concentration value of particulate matter in the atmospheric environment is converted into the density of the main pollutants in the air as equivalent particles, which is suitable for ordinary indoor and outdoor atmospheric environments.

Communication protocol command format:

Characteristic byte 1	Characteristic byte 2	instruction byte	data byte 1	data byte 2	Check byte 1	Check byte 2
0x42	0x4d	CMD	DATAH	DATAL	SUMH	SUML

Check word generation starts from the characteristic word and accumulates all bytes.

Instruction and data byte definitions:

CMD	DATAH	DATAL	说
0xE2	X	X	passive reading command
0xE1	X	0x00-passive mode 0x01-automatic mode	Mode switch command
0xE4	X	00H-Standby mode 01H-Normal mode	Standby control

x represents any value



## MPM12-BG

### Air Laser Particulate Matter Sensor

The host sends the corresponding command, and the module responds:

0xE2: The module responds to output 32 bytes of data, which is the same as the automatic output data format.

0xE1: The module switches the output mode, if it switches to the automatic mode, it will automatically output the data.

0xE4: The module switches to standby mode/normal mode.

Serial communication application example:

1. Switch to passive mode command:

Send: 42 4D E1 00 00 01 70

Answer: None, stop automatic data output.

2. Passive reading command:

Send: 42 4D E2 00 00 01 71

Answer: 42 4D 00 1C 00 26 00 38 00 44 00 1C 00 2A 00 36 1E 1F 05 B2 01 3D 00 2D 00 11 00 0A 00 00 03 43

PM1.0 measurement value is:  $PM1.0 = 0x00 * 256 + 0x1C = 28$  (ug/m<sup>3</sup>)

PM2.5 measurement value is:  $PM2.5 = 0x00 * 256 + 0x2A = 42$  (ug/m<sup>3</sup>)

Pm10 measurement value is:  $PM10 = 0x00 * 256 + 0x36 = 54$  (ug/m<sup>3</sup>)

3. Switch to standby mode mode command:

Send: 42 4D E4 00 00 01 73

Answer: None, the module enters standby mode.

### ◆ IIC communication protocol

The module works in the slave mode of IIC and can be connected to an external MCU. The communication line needs to be connected with a pull-up resistor.

The slave address of the module device is: 0x4d (7-bit address)

The write operation address of the module is: 0x9a

The read operation address of the module is: 0x9b

When reading the MPM12-BG register data through the IIC interface, the communication timing waveform is as follows:

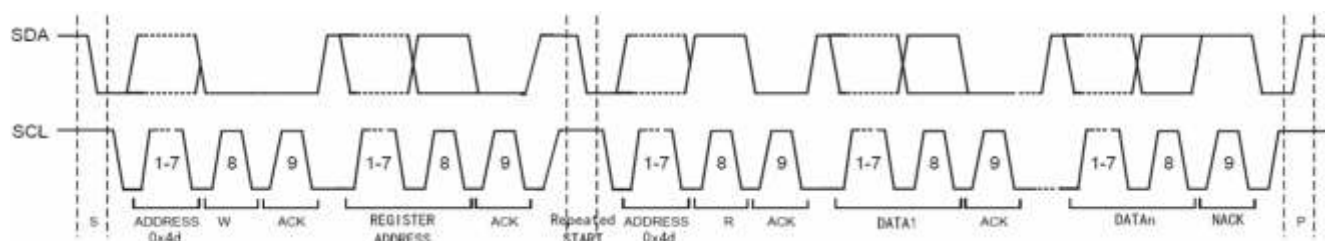

Host sending timing:

1: The host sends the IIC start signal.

2: Sending module device address 0x4d (7 bits) + W (write bits).

3: Send the address of the data register of the module (from which register to start reading, send which address, see Table 1).

4: Send repeating IIC start signal (note that there is no stop signal here).

5: Sending module device address 0x4d (7 bits) + R (read bits).

6: The host receives n bytes of data output by the module (when the host receives data, it sends an ACK signal bit to the module. If the host does not send an ACK signal bit, the module stops data transmission).

7: The host sends the IIC stop signal.

# MPM12-BG

## Air Laser Particulate Matter Sensor

IIC register address and data format

register address	data	explanation
0x20	Data 1 high byte	PM1.0 concentration value (standard particulate matter), unit $\mu\text{g}/\text{m}^3$ *
0x21	Data 1 low byte	
0x22	Data 2 high byte	PM2.5 concentration value (standard particulate matter), unit $\mu\text{g}/\text{m}^3$ *
0x23	Data 2 low byte	
0x24	Data 3 high byte	Pm10 concentration value (standard particulate matter), unit $\mu\text{g}/\text{m}^3$ *
0x25	Data 3 low byte	
0x26	Data 4 high byte	PM1.0 concentration value (in atmospheric environment), unit $\mu\text{g}/\text{m}^3$ *
0x27	Data 4 low byte	
0x28	Data 5 high byte	PM2.5 concentration value (in atmospheric environment), unit $\mu\text{g}/\text{m}^3$ *
0x29	Data 5 low byte	
0x2A	Data 6 high byte	Pm10 concentration value (in atmospheric environment), unit $\mu\text{g}/\text{m}^3$ *
0x2B	Data 6 low byte	
0x2C	Data 7 high byte	The number of particles with a diameter of more than 0.3um in 0.1 liter of air
0x2D	Data 7 low byte	
0x2E	Data 8 high byte	The number of particles with a diameter of more than 0.5um in 0.1 liter of air
0x2F	Data 8 low byte	
0x30	Data 9 high byte	The number of particles with a diameter of more than 1.0um in 0.1 liter of air
0x31	Data 9 low byte	
0x32	Data 10 high byte	The number of particles with a diameter of more than 2.5um in 0.1 liter of air
0x33	Data 10 low byte	
0x34	Data 11 high byte	The number of particles with a diameter of more than 5.0um in 0.1 liter of air
0x35	Data 11 low byte	
0x36	Data 12 high byte	The number of particles with a diameter of more than 10um in 0.1 liter of air
0x37	Data 12 low byte	

\*Note: The standard particle mass concentration value in the table refers to the mass concentration value obtained by using industrial metal particles as equivalent particles for density conversion, which is suitable for industrial production workshops and other environments. The mass concentration value of particulate matter in the atmospheric environment is converted into the density of the main pollutants in the air as equivalent particles, which is suitable for ordinary indoor and outdoor atmospheric environments.

# MPM12-BG

## Air Laser Particulate Matter Sensor

### ◆ PWM output method

The period of PWM is 1000ms

In the initial stage, the low level output is 0.25ms

Middle cycle 999.5ms

End stage high level output 0.25ms

The calculation formula for obtaining the current PM2.5 concentration value through PWM:

$$PM2.5 = 4000 * ( TL-0.25ms ) / ( TH+TL )$$

PM2.5 is the calculated PM2.5 mass concentration value, the unit is ug/m3

TH is the time that the output is high in one output cycle

TL is the time when the output is low in one output cycle

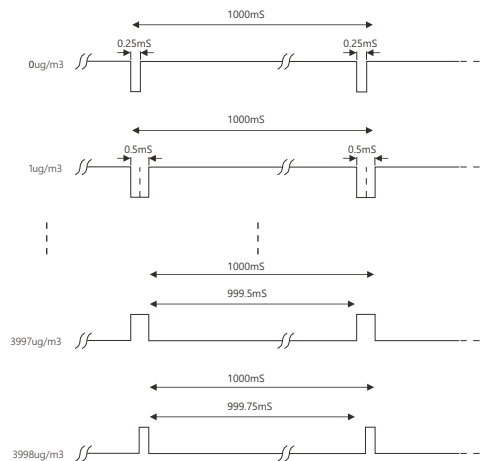

### ◆ Installation Precautions

1. The metal shell of the module is connected to the internal power supply ground. Be careful not to short-circuit with other circuits or the chassis shell.
2. It is the best installation method that the plane where the air inlet and air outlet are located is close to the air hole on the inner wall of the user machine that communicates with the outside world. There should be a structure between the air inlet and the air outlet to isolate the airflow to prevent the airflow from directly flowing back from the air outlet to the air inlet inside the user machine.
3. The ventilation hole opened for the air inlet on the inner wall of the user machine should not be smaller than the size of the air inlet.
4. When applied to purifier products, try to avoid placing the module directly in the air duct of the purifier itself. If it is unavoidable, an independent structure space should be set up separately, and the module should be placed in it so that it is connected to the purifier itself. Air duct isolation.
5. When applied to purifiers or fixed testing equipment, the module position should be more than 20cm above the ground. Otherwise, it may be polluted by large dust particles or even flocs near the ground, causing the fan to wind up and stop rotating.
6. When the module is applied to outdoor fixed equipment, the protection against sandstorms, rain and snow, and willow catkins should be completed by the equipment.
7. The module is an integral component, users should not disassemble it, including the metal shielding case, to prevent irreversible damage.

### ◆ Number Description

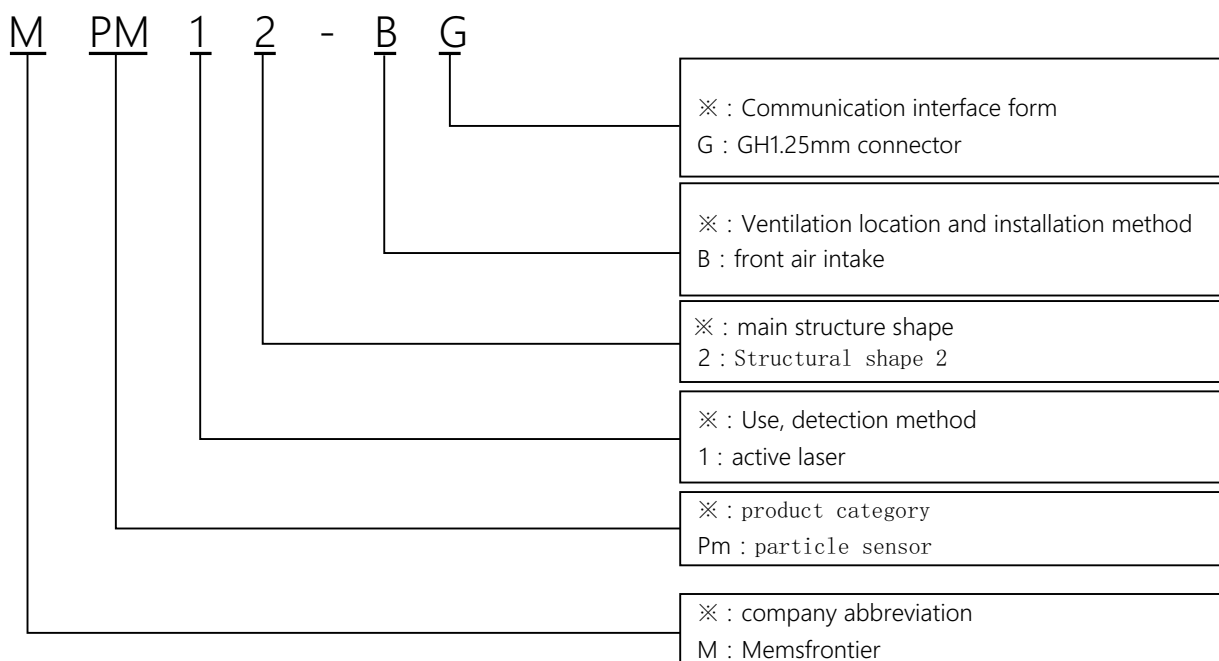



**MPM12-BG**  
Air Laser Particulate Matter Sensor

◆ Packing

Quantity per plate	Packaging layers	Packaging Quantity	carton size	Packaging material
45	15	675	L530*W320*H250	red pearl cotton

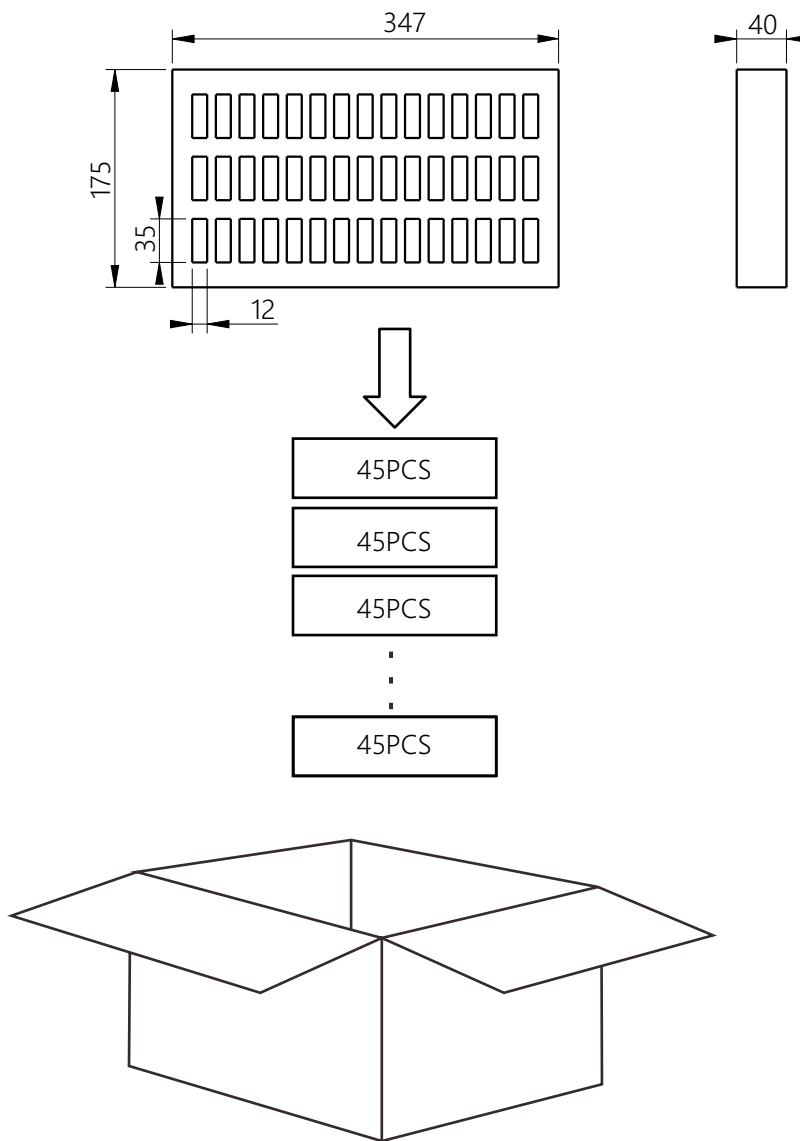

◆ Version history

date	version	change
2022.1.5	1.00	initial version
2022.7.20	1.10	Add the description of the number and the category of the packaging method