

Arducam[®]

Datasheet

AR0230 2MP USB2.0 WDR Camera Module

B0438

CONTENT

1. Purpose
2. Effect
3. Technical parameters
4. Overall Dimension Diagram
5. Lens Diagram
6. Imaging
7. Camera Parameters Interface
8. Function Inspection Criteria
9. Visual inspection criteria
10. Reliability Test
11. Packaging requirements
12. Other

Version	Compile	Auditing	Authorize	DATE
V1.0	Bin L	Kai Z	Lee J	24.03.2023

1. Purpose

In order to fully describe the technical specifications referred to in technical cooperation, it usually needs to be expressed by a complete set of documents. As part of this, this datasheet specifies the specific technical specifications that a camera module should meet and is binding on this model.

2. Efficacy

This datasheet shall prevail if this it's inconsistent with the specifications in the general technical specifications of such goods.

3. Technical Parameters

Items	Parameters
Sensor	1/2.7" AR0230
Maximum Effective Resolution	2MP 1920(H)x1080(V)
Data Format	MJPEG/YUY2/H.264
Pixel Size	3.0 μm x 3.0 μm
Dynamic Range	Up to 96dB
Lens	FoV: 95°(H)
	EFL: 2.8mm
	Mount: M12*P0.5mm
IR Sensitivity	Integral 650 IR filter, only visible light
Frame rate	MJPEG 30fps@1920 x 1080/1280 x 720/640 x 480/320 x 240; YUY2 5fps@1920 x 1080/1280 x 720; 25fps@640 x 480/640 x 360/320 x 240; H.264 30fps@1920 x 1080/1280 x 720/640 x 480/640 x 360/320 x 240;
Auto control	Brightness, Contrast, Hue, Saturation, Sharpness, Gamma, White Balance (Auto), Backlight Contrast, Gain, Exposure (Auto)
Input Voltage	DC 5V
Working Current	MAX 300mA
Operating Temp.	-4°F~158°F (-20°C~+70°C)
Cable Length	Default 1M
System Compatibility	Windows XP(SP2,SP3),Vista,7,8,10, Linux and Mac with UVC driver
Connector No.	B4B-ZR
Dimension	38mmx38mm x21mm

4. Overall Dimension Diagram

Unit: mm

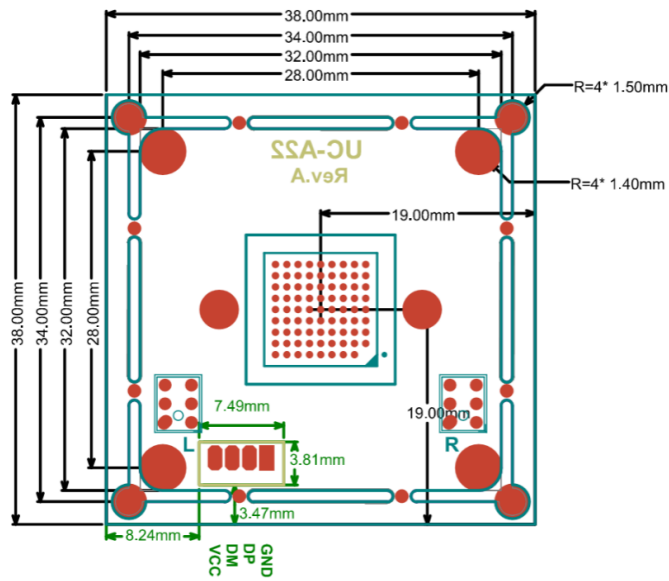

5. Lens Diagram

Unit: mm

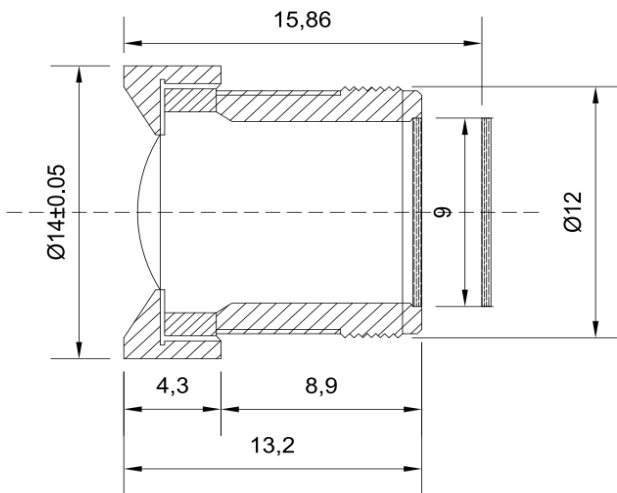

6. Imaging



7. Camera Parameters Interface

- Video Proc Amp

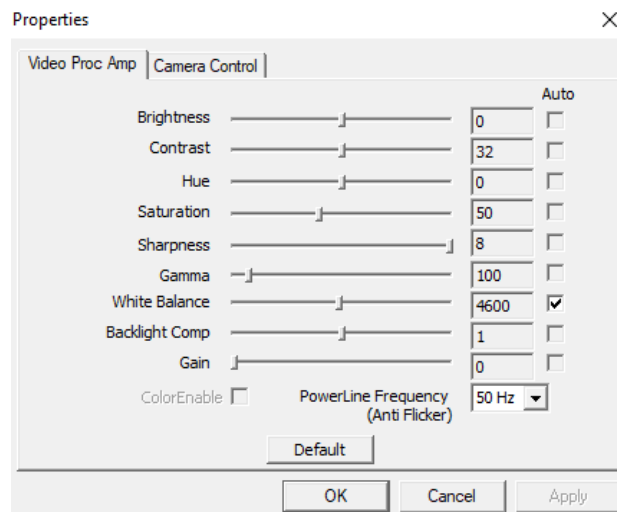

- Camera Control

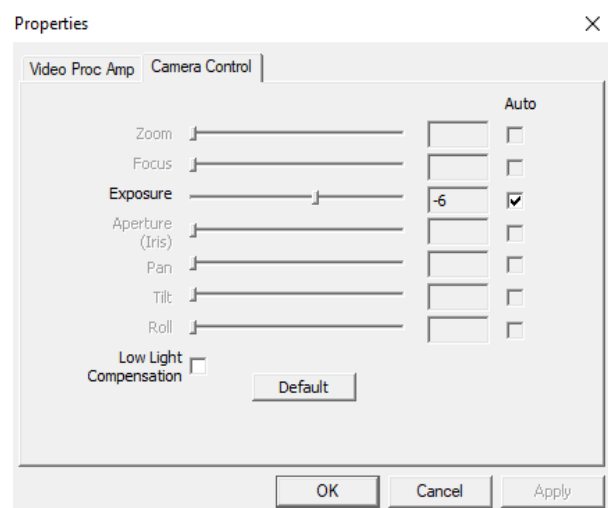

- Video Capture Pin

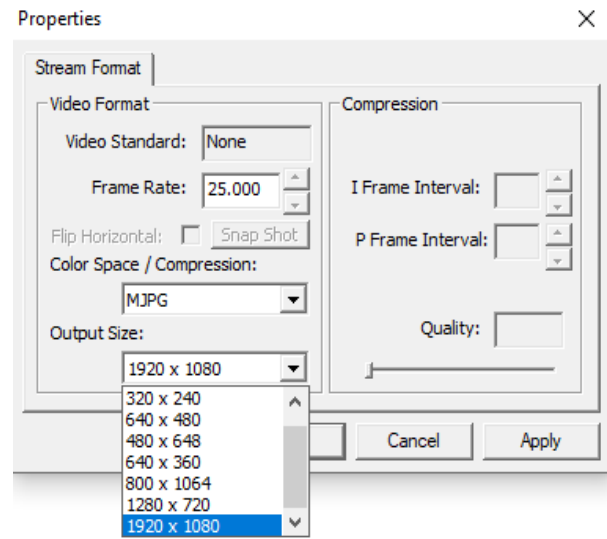
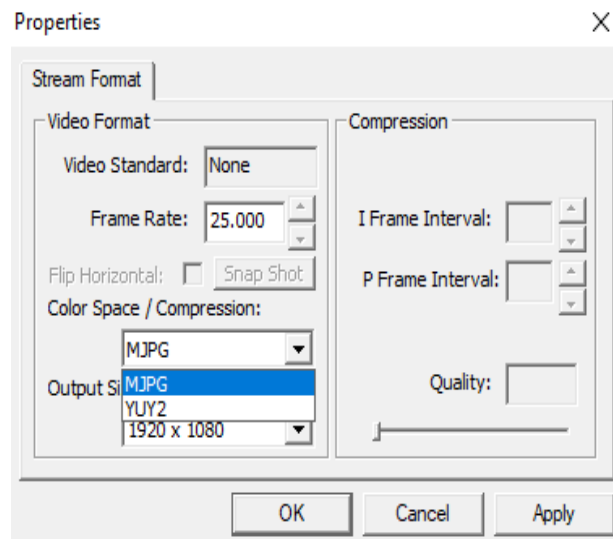

8. Function Inspection Criteria

8.1 Function definition:

Camera module electrical performance and image quality.

8.2 Inspection methods

- Staff: Visual inspection personnel need to be trained and have normal color recognition ability. Their vision should be above 1.0 (or more than 1.0 after correction is acceptable), and their color discrimination ability can pass standard tests.
- Tool: Connect the computer, inspect images with Amcap software.
- Distance and Time
Observation distance: 30~55cm
Observation time for each surface: 3~5seconds
- Inspection condition: Visual inspection should be performed under unobtrusive fluorescent lamps, and its minimum illumination should be above 100 feet of candlelight, or 60W fluorescent lamps, inspected at 1.5m distance.

8.3 Accept criteria

- The image has no mess, color screen and discoloration.
- There is no white spot, black spot, dirt or dark angle in the image.
- The image is same clear on all corners

9. Visual Inspection Criteria

9.1 The definition of the appearance

Camera module appearance.

9.2 Test methods

- Staff: Visual inspection personnel need to be trained and have normal color recognition ability. Their vision should be above 1.0 (or more than 1.0 after correction is acceptable), and their color discrimination ability can pass standard tests.
- Distance and Time
Observation distance: 50~75cm,
Observation time for each surface: 3~5seconds
- Inspection condition: Visual inspection should be performed under unobtrusive fluorescent lamps, and its minimum illumination should be above 100 feet of candlelight, or 60W fluorescent lamps, inspected at 1.5m distance.
- Observation angle: Observation angle between 40°~50°.

9.3 Accept criteria

- Cleanliness: Parts must be free of stains, dust, grease, and other stains. Smudges due to transportation materials are acceptable if they can be blown away or wiped off.
- Assembly surface: The parts to be assembled should avoid scratches, gouges, dents, bends, cracks, indentations, abrasions or other defects caused by improper assembly.

10. Reliability Test

Items	Condition	Specification
High Temperature Test	Temp.: 65°C	No abnormal
	Time: 96H	
Low Temperature Test	Temp: -20°C	No abnormal
	Time: 96H	
Humidity Test	Temp: 60°C	No abnormal
	Humidity: 80-85%	
Cable Tensile Strength Test	Time: 24H	No abnormal
	Loading weight: 4KG	
	Time: 60s	
Drop Test	Hight: 60CM	Electric normal
	Number of times: 10	

	On the wood	
Vibration Test	Vibration machine vibration frequency to 50Hz	Electric normal
	Vibration amplitude: 1.5MM;	
USB Connector	Vibration time: 30 Minutes	Electric normal
	Number of times: 25	

11. Packing Request

- Products should be strictly based on product characteristics to develop corresponding packaging standards and follow the implementation to ensure that the product is used within the specified use and storage period, to achieve anti-static, moisture-proof, shock-proof, mildew-proof, anti-barbaric handling and other signs and related warranty requirements. Product packaging should be marked: Supply-side name / logo, Product Model specifications, containing the number, production date / batch number and order number.
- The product's outer packaging should be marked with: supplier name / sign, product model specification, built-in quantity, production date / batch number and order number.
- The packing and packing scheme are based on the customer's requirements, and the two parties will negotiate the specific details. The sealed samples shall prevail.

12. Others

- Changes to this acknowledgement need to be confirmed by both parties, and any modification by either party is invalid.
- This acknowledgment must be signed and returned within seven working days of receipt by the client, late regarded as the default.